

# METALLIC CARTRIDGES,

(REGULATION AND EXPERIMENTAL,)

AS

MANUFACTURED AND TESTED AT THE FRANKFORD  
ARSENAL, PHILADELPHIA, PA.

---

PREPARED UNDER THE DIRECTION OF THE CHIEF OF ORDNANCE BY

MAJOR T. J. TREADWELL, ORDNANCE DEPARTMENT,  
COMMANDING FRANKFORD ARSENAL.



WASHINGTON  
GOVERNMENT PRINTING OFFICE.  
1873.

550  
ont

FRANKFORD ARSENAL,  
PHILADELPHIA, P.A.,  
April 22, 1873.

SIR:

The following notes on the performance of metallic cartridges manufactured and offered at this Arsenal for service, comparative trial, and experiment, have been prepared with a view of presenting the subject in a brief, comprehensive manner for the information of the Department, and are submitted with the hope that they may not prove uninteresting.

As the investigation of the whole subject of metallic ammunition for small-arms would open up a field of research far beyond the limits of the present purpose, it has been deemed best to confine its treatment in a general descriptive manner to the development of the question, based upon trials made by the Ordnance Department, particularly at this Arsenal.

Most of the prominent varieties of cartridges herein referred to having been the subject of extended trials, the results of which have been given in full and special reports to the Bureau, the details of their performance have not been attempted in this place.

I am indebted to Mr. Jabez H. Gill, foreman of machine-shop at this Arsenal, for the preparation of the very creditable drawings accompanying this Memorandum, as well as for valuable suggestions of forms and combinations used in the purely experimental cartridges herein described, and for assistance in the comparative and extraordinary tests that have been applied to determine the relative value and strength of cartridge-cases as developed by hydrostatic pressure, test eprouvette, &c.

The mode of application of the pressure-gauge, as described in the accompanying drawing, was devised by Lieutenant William Prince, Ordnance Department, and adapted to the Springfield breech-loading rifle, with most satisfactory results.

I have the honor to be, very respectfully, your obedient servant,

T. J. TREADWELL,  
Major of Ordnance, Commanding.

To the CHIEF OF ORDNANCE, U. S. A.,  
Washington, D. C.

The following notes on metallic ammunition are prepared and submitted to the Ordnance Bureau, not with a view of discussing the whole question or chronological progress made in the preparation of this kind of ammunition, but, more particularly, to give information as to the results of experience in manufacture and experimental trials of metallic cartridges, as fabricated and tested at the Frankford Arsenal.

In this connection it is not deemed out of place to touch briefly upon breech-loading small-arms, and the great advance made in their mechanical ingenuity and perfection, which, combined with the introduction of metallic self-primed ammunition in their use, overcame the prejudice against their general adoption into military service which prevailed, to a very decided extent, only a brief half-score of years since.

Considerable attention was given to the subject and production of breech-loading small-arms in this country some twenty years ago, and their invention was stimulated by legislative enactment and appropriation. It was at that time designed, however, and for some years later, to produce a suitable arm for mounted troops; one that was safe and more readily manipulated in the saddle than the muzzle-loading rifle or musketoon with swiveled or separate ramrods, and provided with a cartridge not requiring so great a number of motions in loading and firing.

Breech-loading small-arms had been known and experimented with many years before this. It is not within the scope of this article to treat this branch of the subject historically, but simply to briefly state by what rapid growth, of late years, breech-loading small-arms, from very indifferent models giving more indifferent results in practice, have advanced in general and universal use in all arms of service, among almost all civilized nations, and to what a surprising degree of perfection they have been brought.

No branch of invention has been more rapidly or beautifully developed and improved in the past ten years, especially in the United States, than that under consideration; and it is believed that it may be fearlessly asserted that the use of expanding metallic self-primed ammunition, acting as a perfect gas-check to breech mechanism, has been the chief cause of rendering effective the very many existing breech-loading systems now claiming attention in this country and abroad, which would otherwise be useless and worthless.

In the earlier stages of the solution of the problem of the production of an efficient breech-loading rifle, paper and linen ammunition was used, but the perfect *fermeture* of the joint between the breech mechanism and barrel was never successfully accomplished until the adoption of expanding cartridges, although some of the earlier arms were very ingenious, and found to give good results in practice. Among them may be named the justly celebrated, and perhaps most prominent and popular, Sharps' rifle and

carbine, which, as is well known, has given an excellent record of its performance in the field and on the experimental ground. These arms were most excellently well-made weapons, and believed by many military authorities to be the very best breech-loader produced for the use of paper or linen cartridges. The gas-check in this arm was an expanding metallic ring in the breech-block, which did its work well. Other meritorious systems, with ingenious means of closing the breech-joint, were in use, with fair results, but by far the most numerous varieties were not effective systems, and, in fact, were only tolerated and used in consequence of the dire emergency of immediate warfare, and the necessities of the armies.

For a long time the idea of the *general* adoption of breech-loading arms for troops of all services met with almost no encouragement among military men, and it was not until as late as after the battle of Gettysburgh that it became popular and prevailed in the service. This prejudice once overcome, by what may be fairly termed an entire revolution of the character of the arms and ammunition, the new breech-loaders became rapidly popular, and gained many advocates throughout the Army, where their great superiority to the old muzzle-loaders is now universally recognized and assured. The use of some effective breech-loaders and magazine-arms had, for some time, popularized them for cavalry, but many of the best infantry and artillery officers were adverse to their employment by foot-soldiers. A marked contrast of the two systems was furnished the Department by the recovery of upwards of 25,000 stands of muzzle-loading arms from the battle-field of Gettysburgh. These were sent to the Washington Arsenal, and there overhauled and examined, and were found to be nearly all loaded; some with one, two, three, four, six, and even as many as twenty rounds of cartridges in the barrel. This fact gave an active impulse to the necessity for an arm which, by its construction and cartridge, could never produce such a result as the above, and which, by materially reducing the motions for loading and firing, was capable of greatly enhancing the power of the individual soldier.

As an advancing step in the right direction, various systems of breech-loading arms had been devised, using, instead of paper or linen, metal cases holding the powder and bullet, but not as yet self-primed. Among ingenious samples of these may be named the Burnside, Maynard, &c., &c. Still further progress developed more perfect systems using self-primed ammunition, including magazine-arms, as Spencer, Henry, &c., and the speedy adaptation of all then known systems of any pretension to the use of such ammunition. In the past few years, in this country at least, only such breech-loading arms as were so adapted or originally devised, stood the least chance of success in the many contests that have been had for supremacy.

The various steps in the invention and perfection of ammunition suited to breech-loading arms had, in the meantime, been as numerous and progressive as those for the perfection of the arms themselves.

In the earlier varieties of the metal cartridge, the primer or cap by which it was fired was detached from the cartridge, as in the Burnside, and Maynard, &c., the cap being applied to a cone, as in muzzle-loaders, and the flame of it having to penetrate through the devious channel of the vent of the arm to the vent in the rear end of the cartridge, causing a considerable percentage of failures to ignite, due to fouling the vents, &c.

A great step in improvement and advance was the combination of the primer and

cartridge. This was variously effected by introducing the priming composition into the folded rim of the head, where it was distributed by swirling, as in the Spencer and other well-known varieties of so-called rim-primed ammunition; by introducing a primed cap into the cartridge, connecting this with a wire projecting from the case, or other means by which to strike the primer, as the Lefauchaux, &c. Still another step was the introduction of center-primed metallic cartridges, either primed internally, as in the present Service, the Martini, and many others, or, externally, by use of a primed cap and anvil, inserted in a suitable pocket in the head, as the Berdan of the Bridgeport Company's manufacture, the Millbank, and many others; in fact, the varieties and inventions of these center-primed cartridges are very numerous, both methods of priming having been largely and successfully adopted, both by national works and private companies.

A very excellent wrapped-metal cartridge has been successfully experimented upon and produced in large numbers in this country, where this very ingenious invention and application was originated, and where it is believed to have been produced in its greatest perfection; and in England, where it has been very extensively used and tested experimentally, improved, and finally adopted under the name of the Boxer cartridge for use in their latest model Martini-Henry breech-loading rifle, also adopted by that government, and now acknowledged to be a modification of the American invention, under the name of the Peabody system. A wrapped-metal cartridge somewhat similar was also used with the English Snider rifle.

The combination of primer and cartridge still further reduced the number of motions necessary to manipulate the arm, and greatly increased its efficiency.

The machinery for production of metallic ammunition, both in the Government and private factories, has been brought to a high degree of perfection, its very beautiful and almost automatic character and performance, uniform and accurate production, making it the admiration of the beholder. As these machines have been developed and improved in the Government shops, many ingenious devices and combinations have been invented and perfected, under the direction of the officers of the Ordnance Department, aided by the high skill of the ingenious mechanics in its employ.\* In the private cartridge factories of the country, also, many skilled workers and inventors have grown up contemporaneously. A very generous and free interchange of thought and design, and unselfish exchange of information on the subject generally, has had the effect of spurring to combined exertion and improvement, being fruitful of new ideas, and tending greatly to advance the work to its present very satisfactory state, while the almost daily list of new inventions demonstrates that the problem is by no means used up or exhausted. The very rapid advance and excellence of material now produced may be referred to with just pride, in view of the fact that it is perfectly safe to assert that the best of metallic ammunition now in use in foreign countries, as well as our own, is the result of American (United States) invention and genius.

Having touched thus generally on the subject of breech-loading small-arms and

\* Mr. R. Bolton, the master armorer, and Mr. Jabez H. Gill, the foreman of the cartridge factory, at Frankford Arsenal, may, without invidious distinction, be named as having brought to the work, from its inception, the highest order of mechanical skill, ingenuity, invention, and adaptation; and to their zeal, efficiency, and untiring effort the acknowledged degree of perfection of our present service metallic cartridge is largely due.

their ammunition, it is now proposed to submit, briefly, with suitable illustrations, the results of such experiments and tests with self-primed metallic ammunition as have been developed and carried out at this Arsenal, as well as the tests of such other varieties of metal cartridges as have been offered by other makers for comparative trials.

For the purpose of a clearer understanding of the several forms of metallic cartridges experimented upon and in use, they are classified as follows :

First. Those in which the shells are made of continuous metal, combined with a suitable primed-anvil, but not re-enforced in the head ; *e. g.*, the service folded-head cup-anvil cartridge.

Second. Those in which the shells are made of continuous metal, or of combinations of pieces of metal, combined with a primer, with and without a separate anvil, and are also re-enforced in the head ; *e. g.*, the Berdan.

Third. Those in which the body of the case is of continuous metal or several parts, and have a solid or other suitable attached head, properly primed ; *e. g.*, the Boxer.

Fourth. Those made with a solid head of metal, continuous with the case, and suitably primed ; *e. g.*, the Hotchkiss and United States Cartridge Company, (Farrington.)

These several classes, that have been tested here, are given with illustrations, showing their combination and parts, and with brief explanations as to their fabrication, the results of their trial, and sufficient details of their parts and manner of assembling to give a general idea of their construction.

That the present degree of perfection in the manufacture of these several classes of metal cartridges has been the result of gradual and careful development, is evident from a cursory examination and comparison of the earlier, intermediate, and more recent best forms.

Among the first of metal cartridges of American invention is the Morse, which was brought out a short time before the war of the rebellion, but not thoroughly experimented with at the time or introduced into service. Its objectionable features are apparent in the light of progress made. Its merits over paper or similar ammunition are apparent, the chief, perhaps, being that it was designed as a self-primed cartridge, had a flanged-head for extracting the case, and that it reduced the operations of loading.

About the same time the Burnside, Maynard, and a few others, were produced, some of which were good in their day, and for the arms for which they were designed, but were fired by means of a cap, through a vent, at some distance from the cartridge, and were extracted by the fingers. With them there was not that necessary nicety of fit to the chamber of the gun, the joint was not absolutely closed, and the failures to explode were as frequent as with the old-fashioned paper cartridge and percussion-cap. Such failures would, now-a-days, be considered a most unwarranted percentage in any metallic ammunition laying claim to excellence, and, in the best known varieties, do not occur to the extent of one in one thousand rounds ; in fact, many attain a much higher standard of surety than indicated by this figure. The records of the testing-grounds show long-continued firing and consumption of thousands of rounds without failure at all from any cause, and the summation of a year's practice and test, in proof of manufacture, exhibits but an exceedingly small percentage of such failures.

For some time the idea of combining the primer and cartridge did not assert itself, but some inventions were pushed in this direction, and the rim-primed cartridge was produced. In this the fulminate composition was placed in the folded head of the case.

This mode of priming requires a large charge of the priming composition, which, being thrown into the fold by swiveling, the entire circumference of the head was not always primed thoroughly, and as the cartridge is exploded by striking the rim at a part of the head under the hammer, it not infrequently happened that it failed from the point struck not having any priming. The large charge required, also, (about 5 grains against  $\frac{1}{2}$  grain for the center-fire,) was a further objection to rim-priming ; the exploding of so large a quantity of quick-powder in the folded-head, the weak part of the cartridge, tending to strain and open the fold to bursting, as it frequently did. Another objection to rim primed cartridges is that they are more liable to accident in handling, and in shocks of transportation, and those incident to service ; in fact, a number of instances of explosion in the magazine of repeating-arms, and in patent cartridge-boxes for service of such, have been reported, by which serious injury resulted to the soldier.

Hence, efforts to produce a still more reliable and satisfactory cartridge, and the development, production, and general adoption for service of what is now so well known as *center-primed metallic ammunition*, its advantages being sure explosion when struck by the point of the firing-pin ; less of fulminate and less strain on the head of the cartridge ; greater security in handling and using under all exigencies of service. These cartridges have been subjected to the severest tests to demonstrate their capability to resist all accidents, such as mashing up boxes of ammunition, and even firing into them with bullets. Only the cartridges actually impinged upon exploded under such tests, their neighbors being only blackened and not otherwise damaged. The safety of handling and transporting this ammunition in comparison with that of the old-fashioned kind is vastly in its favor, and the risk attending its carriage is almost nothing. Its greatly superior quality to resist exposure of climate, moisture, &c., has also been proven by such severe tests that it may be asserted to be practically water-proof. A central and direct blow on the point primed is an essential and highly important feature of the center-primed cartridge ; its general adoption, and the adaptation of all breech-loading service small-arms to its use, is the best proof of its acknowledged superiority. Simple modifications of the form of the head adapt it to safe use in magazine arms, even though the front of one bullet rests on the head of the preceding cartridge, while with all varieties of repriming ammunition the central fire is a *sine qua non*. Other reasons in its favor might be given, but it is believed sufficient have already been adduced to warrant the statement that whatever may be claimed as the particular merit of any one variety of metallic ammunition, by ardent inventors or admirers of special forms, all are agreed that, for military purposes at least, the palm to center-priming must be yielded.

The service-cartridge, made of a copper case with a folded-head and copper fulminate primed cup-anvil, crimped in position, has been so long used and tested on the experimental ground and in the field, and by various boards of experts on small-arms, and its excellence in all these fields of trial so well demonstrated, that no particular description of its construction and performance is here necessary. Some of the varying modifications of the folded-flange cartridge are noted in the drawings.

It is of rare occurrence that the fold is sometimes slightly opened or burst in firing, probably from a defect or thinness of metal, but this is not attended with the least inconvenience or risk to the person or arm, and, in most cases, would escape notice altogether outside the carefully scrutinized cases used at the experimental and testing grounds.

So far, this has not been deemed of any consequence in the service, and none of the best model breech-loading arms take the least notice of it. If necessary, however, the folded-head cartridge is abundantly susceptible of improvement, in an easy and practicable manner, as is evident from an examination of the various forms of re-enforcement of cartridges of this construction, experimentally tested and herein described.

\*Of class second, one of the best and most extensively made and experimented with is the Berdan, as made by the Union Metallic Cartridge Company, of Bridgeport, Connecticut, in large numbers, for the Russian government, for use in the Berdan breech-loading rifle. This cartridge has been most strictly and severely tested during their manufacture, and has proved of great excellence. It is exceedingly ingenious; its re-enforcement simple and effective; its capacity as a reloader fully tested and demonstrated by prolonged and repeated trial, daily, during production of millions of rounds; a number of the shells being reloaded, primed, and fired ten times, and much more extended trials have been had for special test of the endurance of the cases in this particular. Its chief distinguishing feature is that its anvil is of the same continuous piece of metal as that of which the case is made. Herein there is no possible displacement or misplacement of the anvil, and it has a fixed position with respect to the primer. The cartridge is singular in this respect, and superior to its rivals that require a separate anvil. In it was a very happy idea hit upon by the inventor of making his anvil by a simple return of the metal of the pocket for the primer. All other anvils are its inferiors in that they have to be handled in assembling the parts of the shell. Another advantage is, it presents a point to the primer inside, rendering it sensitive to the blow of the hammer. The use of the special Hobbs' primer is most excellent in this combination. Other varieties of an excellent re-enforcement may be referred to, as exhibited in the drawings and notes under this class.

These re-enforcements may be accomplished in various ways, as by a ring of expanding metal, a ring of solder, felt or *papier-maché* wads, &c. When the ring of this metal is used as a re-enforcement it is best applied, and perhaps only effectually, in those cartridges having a pocket or return of the head for the priming. In these cases it should be so formed as to act by expansion against the walls of the case and of the pocket, to cut off the escape of gas to the folded head in both directions.† The solder ring has been found to be a good re-enforce also, and in the wrapped-metal and some other varieties of cartridges it serves also to attach the flanged-head to the body of the case. It was first used here for this purpose, and that it acted also as a re-enforce was a resulting discovery. The felt or *papier-maché* wad is not believed to be as good or to hold the head as securely, although it is extensively used in the various forms of Boxer ammunition. It is not believed that a simple ring of any soft metal of any shape, as lead or its alloys, forced into the case at the head, will act as a re-enforce, as has been claimed. No matter how closely the metallic surfaces are in contact, if the re-enforcement does not expand more promptly and as fully as the case itself under the pressure of the

\* The object of a re-enforcement to the head of a folded metal cartridge, is to guard against defects in metal undeveloped in the process of manufacture, and not eliminated in the inspection of cases. As it is hardly likely that a defective case and defective re-enforcement will be assembled in the same cartridge, it is effective.

† Some cartridge-cases were made of brass, re-enforced with plumbago and beeswax, and tested. The re-enforcing material seemed to flow under the gas pressure, affording but little protection to the case.

gun, it does not strengthen or re-enforce the point to which it is applied. A re-enforcing plug works well, applied to a Martin cartridge, as well, in fact, as to a Berdan, and in the same manner. An objection to the Martin is its small anvil for small-headed cartridges, and their liability to burn the priming composition inclosing the pocket on the anvil, a difficulty met with in their manufacture here, with the bar-anvil, and which can only be wholly eliminated by careful inspection of primed cases.

The Martin, as made by the inventor's first patent, without the re-entrant fold, is a good cartridge, and has given good results. The Martin, with the re-entrant fold, which for some time was believed to be a most admirable feature, was, on more extended trials, found to be liable to burst through the re-entrant fold, leaving the body of the case in the chamber of the gun, or shearing the case and tearing off the head by the extractor in opening the breech, temporarily paralyzing the arm. This peculiar accident did not develop in the firing of a large number of rounds, even when it was reported to have occurred in service. Thousands of rounds were fired before it was met with here, but it is of such a dangerous and fatal character to the arm when it occurs as to render it the most formidable of all causes of failure, and led to the abandonment of their manufacture. An inspection of the drawings showing the construction of these cartridges, with those of tests with the *eprouvette*, will fully explain the cause and manner of the failure in question. When the metal was thoroughly sound and not demoralized in manufacture, the re-entrant fold gave great additional strength to the head, and, as will be seen from the tests, enabled it to stand excessive charges and strains, but it would not answer to risk the manufacture of cartridges by the million that were liable to the defect above noted, even to the extent of 1 in 50,000. Defects which other cartridges have, rendering them liable to fail from any cause whatever, (to a very small fraction of per cent. in most good varieties,) involve only the loss of a single shot or charge, but leave the arm in perfect working condition; but tearing off the head, the body of the case is carried forward by the bullet and wedged so tightly in the chamber as to require extraction by mechanical means; the arm is consequently useless until the obstruction is removed.

Perfection in metallic ammunition can hardly be expected, but the percentage of failures is already so small that we may reasonably hope to reduce them to such a degree that, considering the rapidity of fire of breech-loading arms, they may be regarded as next to nothing.

With regard to such wrapped-metal cartridges as come under this class, it may be added that they are easily re-enforced, are cheap, require little plant, less skilled labor than other varieties, could be produced at various points in number in an emergency, and by suitable packing can be protected from moisture and shocks of transportation, except, perhaps, that incident to their use on the person of the soldier. They extract with ease, and in the tests have given good account of themselves. Those that have been made at this Arsenal are intended to be referred to in these remarks. Some of these cartridges were exposed for six months to an atmosphere saturated with moisture, and five of them fired for velocities without drying. They gave a mean average of 1,125.1 feet; loss of about 10 per cent. Another lot exposed in the same way for a year, and thoroughly dried before testing, gave a mean average velocity of 1,256 feet, which is a fair average mean. Service cup-anvil cartridges similarly exposed showed no deterioration at either trial.

Of class third perhaps the most notable and most extensively made is the Boxer, as made at the Royal Arsenal, Woolwich, for the Snider and Martini-Henry rifles; not that it is believed to be the best, but from the fact of its adoption by the English Government, and from the very large numbers made and expended in their trials and service. A perusal of the English reports of their small-arm ordnance board will show the most casual reader that the failures of these cartridges, from all causes, have been what would be considered in our trials of the best American cartridges as a very large percentage, sufficient to warrant the abandonment of a cartridge that failed so often. Unlike its American prototype, from which it was originally taken, without, however, giving any credit or compensation to its inventors, its parts are more numerous, and the steps of operations in its production more than double those in that simple cartridge. Its cost, hence, is also large, considering the low prices of labor and materials, and the very large numbers fabricated in the country of its adoption; a cost very much in excess, it is believed, of that of any other of the most approved American varieties of metal cartridges fabricated under similar advantages of cheap labor, low-priced material, and large production. It does not appear to be well adapted to stand the shocks of transportation or exigencies of service, is easily indented and disfigured, so much so as seriously to interfere, sometimes, with ease of loading. Per contra, it is beautifully expanded and brought into shape of the exact walls of the chamber in firing, and extracts readily if the head holds, which, from the reports, seems not always to be the case. It is not suitable in its present state and form for use as a reloader, whatever may be claimed for it in this respect, and it is doubtful if it could be made so. The idea of such a use does not seem to receive encouragement from recent reports. Its attachable heads, from the peculiar and awkward mode of fixing them, are not exact or even, and may not always be firmly put on. Made of iron, it is believed they never should be for cartridges subjected to all varieties of climate. The use of this metal for a cartridge, otherwise so costly, is the poorest kind of economy.

Several varieties of this class have been tested at this Arsenal, as shown, but none have developed any remarkable excellence as compared with the best of the other classes. One variety, believed to be novel, and which may perhaps be hereafter the subject of more successful experiment and production, is the *cast-head*.

Class fourth, solid heads. There are several varieties of these, as the Hotchkiss, the Dutch, the United States Cartridge Company's, &c. The head, here, is re-enforced by using a thick sheet-metal strip to form the case, and leaving sufficient stock in the head, in drawing the case, to flow out and form the flange solidly. That this is effective in making a very strong case is unquestionable; its manufacture requires some heavier plant for special operations; its cost in metal and production is somewhat greater; and it is believed that the head is unnecessarily strong for the present work required by well-constructed breech-loading small-arms.

Experience, it is believed, has fully demonstrated that, in order to insure the best results in service, our small Army should be furnished with the most approved arms and material practicable. To effect this, the careful selection of an excellent (the best if it can be determined upon, for the chief trouble of such a selection seems to be from *embarras de richesse* in this branch of invention) system of breech-loading rifle small-arm, and suitably working efficient ammunition for the service of the same, is pre-eminently desirable. Supposing the first part of the proposition accomplished, and such a breech-loading system selected, approved, and adopted, their production in such

frequent verification of, their tools, dies, and punches, in current use to insure the desired nicety. Without this constant care in keeping up to the standard, work, however satisfactorily and successfully inaugurated, will soon become indifferent.

I am satisfied that the difference in dimensions between the present chamber of the Springfield rifle and other trial arms, and the cartridges used in them, is unnecessarily great, and that it can be reduced to advantage, to the better performance of the arms and cartridges; and as these matters will be of great importance in the event of the adoption of a standard arm and caliber, to insure a correct beginning they should be strictly determined by competent authority. In this connection it may be added that a standard musket powder should also be determined upon.

The copper cartridge case, from its expansion and comparatively small elasticity, does not return to its shape after firing, and could not be used as a reloader without reduction.

The brass case expands sufficiently to act as a perfect gas-check, and by its superior elasticity regains sufficiently its shape to be used as a reloader without reducing, if properly made. For the same reason the brass case extracts more easily than the copper. The wrapped metal case expands by unfolding, and from its somewhat yielding nature extracts easily and can also be reloaded and used without reduction.

All experience shows that the fulminate composition for priming should not be in contact with any easily corroding metal, or so deposited in the primer or in assembling the parts as to render any galvanic action possible for its deterioration and eventual destruction. It is not believed that the service fulminate composition for priming in contact with pure copper undergoes any such deleterious change, as our percussion-caps of twenty years ago are now prompt and perfectly reliable.\* It should not be in immediate contact with brass, however, where brass is used in construction. This is not necessary, as in the Hobbs' primer, for instance, it is efficiently protected by being between two coats of varnish, one applied to the bottom of the cap before the priming is dropped in, the other to one side of a tin-foil varnished disk pressed over the priming, which also holds it securely in place. Similar means of protection are used in other primers, or an equivalent. The United States Cartridge Company's primers, the Millbank, &c., are well protected from moisture, deterioration, and injury.

Competent authority should settle whether outside or inside priming should be

\* *Exposure of fulminate composition upon copper plates.*—Small quantities of priming composition composed as follows: 35 fulminate of mercury, 15 chlorate of potash, 45 glass-dust, 4 gummed water; 35 fulminate of mercury, 15 niter, 45 glass-dust, 4 gummed water, were spread on clean sheet copper, and exposed to an atmosphere saturated with moisture for ten days. It was found, on examination, that in the composition in which niter entered, the niter had effloresced to a considerable extent and crystallized in needles, while that with the chlorate was apparently unchanged. In each case there was a slight discoloration at the seat of contact of the composition and metal. Portions of each were removed from the plates, dried, and tested. The chlorate compound was unchanged and exploded by a blow with the usual quick, strong intensity as before the exposure. The niter compound was quick to explode, but of less intensity of explosion. The former composition is that in use with service primers, and is used at the machine in a wet state; the latter is the old percussion-cap composition, (except that no glass-dust was used,) and was used in a dry state when priming, and protected in the cap by shellac varnish. It would appear that the chlorate composition is preferable for priming metallic ammunition. In some cases mealed powder is used, and makes a good priming, better for the same uses than refined niter. Chlorate composition that had been exposed for five years, on plates in a dry office, was removed and tested, and seemed to have lost none of its promptness or intensity.

exposed for different periods, from one month to upwards of one year, to an atmosphere saturated with moisture. They were of all kinds, musket, carbine, pistol, and revolver. They were packed in paper boxes varnished with shellac. These boxes were reduced to a pulpy mass, and hanging in shreds. Two hundred and fourteen of these cartridges were taken from the vault in which they were exposed, and fired in their respective arms, dirty and dripping with water as they were. All exploded promptly at the first blow, no hanging fires or failures of any kind, and extracted readily. Two cartridges of each box were opened, and the powder found to be in good condition, and priming composition unchanged. Two hundred and ten of the same were placed in the drying-room over the boilers, for a similar period of time, exposed to a temperature of 120° to 130° F. All exploded promptly at first blow, except one cartridge in the Remington pistol, which required two blows. In no case had the lubricant escaped from the case, being undoubtedly retained by the crimp of case on the bullet.

---

## DRAWINGS OF METALLIC CARTRIDGES,

AS MADE AT THE

FRANKFORD ARSENAL, 1860 TO 1873,

FOR

THE MILITARY SERVICE AND FOR EXPERIMENT.

---

# MORSE'S CARTRIDGE

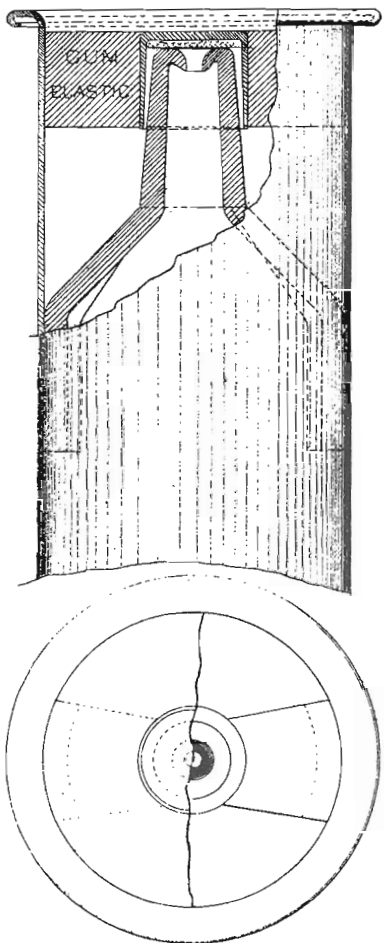

PATENTED  
1858

*Remarks.*

*Claim.*—Attaching invol to side of case and the Elastic Fuse.  
A small number was made at the Frankford Arsenal, 1860.

# BURNSIDE'S

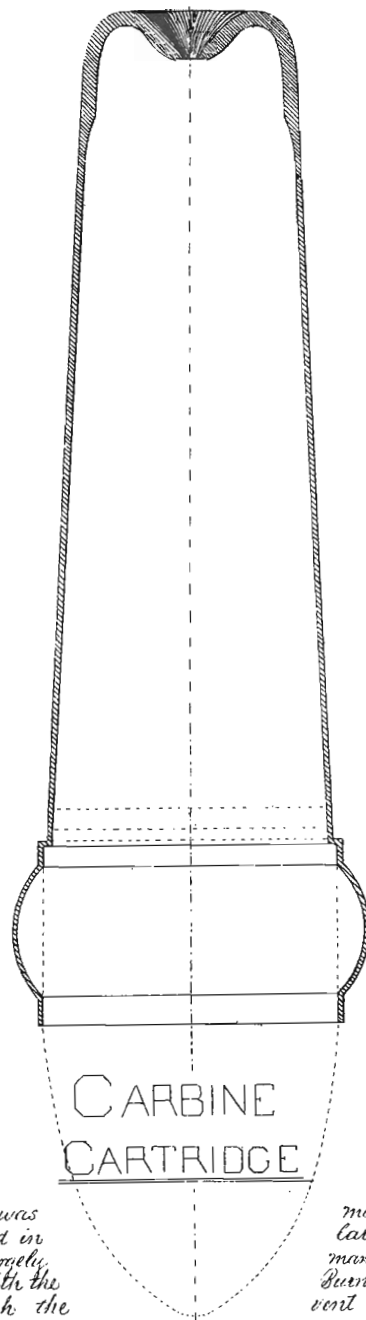

BALL  
400. GR

CARBINE  
CARTRIDGE

POWDER  
45 GR

*Remarks.*—A number was  
Frankford Arsenal and in  
others. They were also largely  
and used extensively with the  
they were ignited through the  
cup

manufactured in 1860 at  
large quantities at subsequent  
manufactured at other factories  
Burnside carbine, metal of brass.  
vent by the ordinary percussion

## MAYNARD'S

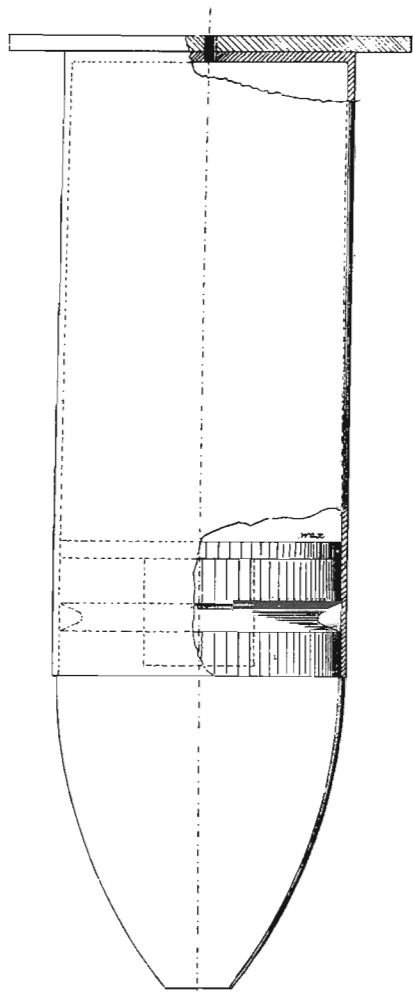

POWDER  
40 GR.

CARBINE  
CARTRIDGE

BALL.  
343 GR.

## Remarks.

*Ignited by a cap through vent hole at head of case. Head soldered on, metal of brass, manufactured, 1860, and at subsequent dates both here and elsewhere and largely used with the Maynard carbine.*

## RIM PRIMED.

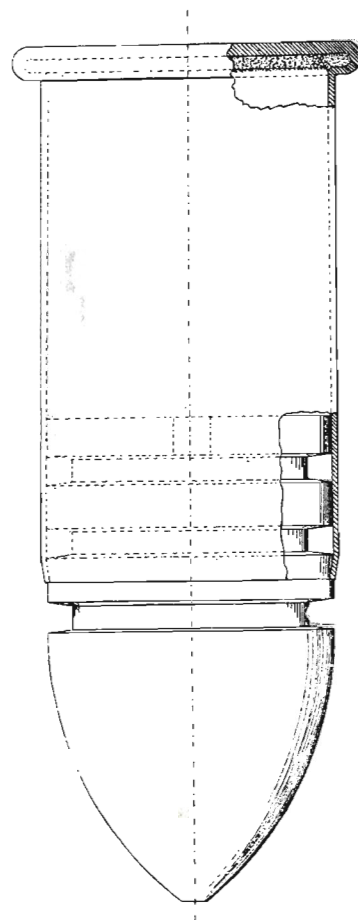

POWDER  
40 GR

SPENCER'S  
CARBINE  
CARTRIDGE.

BALL  
450 GR

*Remarks.— About 50,000 were fabricated in 1864 and 1865. Primed by a centrifugal Machine. Priming in a fluid state, Sharps mixture, consisting of 6 parts by weight, of mealed powder, 3 of Fulminate and 3 of Glass.*

## PRIMITIVE

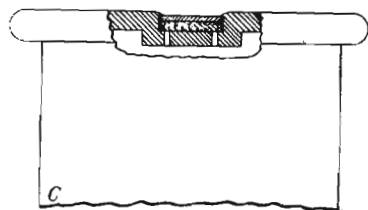
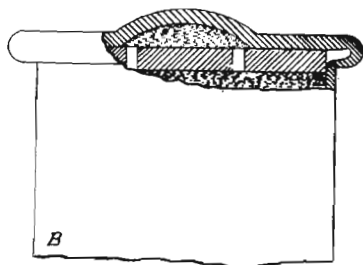
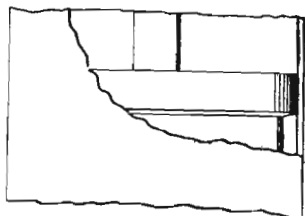
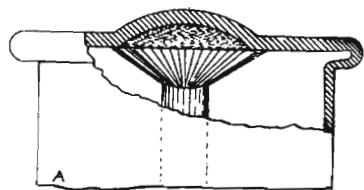

FRANKFORD  
ARSENAL  
1864 1865

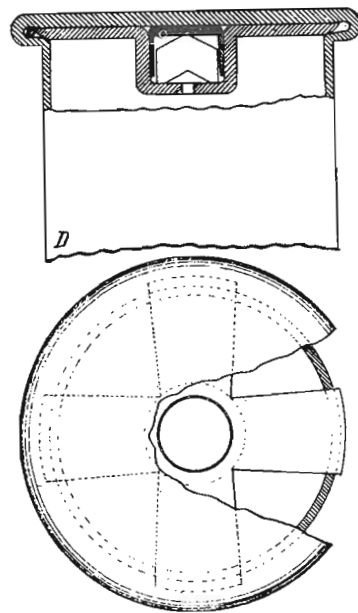

Previous to the year 1866 experience in the manufacture of metallic cartridges at this Arsenal was limited to making a few of the Moore, Punnisides, Haywards and rim-fire cartridges for experimental purposes. In the early part of 1864, Col. Laidley comdg., special machinery. (Draw Russ) was introduced preparatory to making cartridges. In 1865, Col. Bonet comdg., a few experimental "Gatling" 1 in. calibre rim-fire cartridges were made to test the Gatling Gun. In 1866, it being evident that the rim-fire would be superseded by centre-fire, considerable attention was given to the production of a reliable centre-fire cartridge. Samples of the first attempts to make centre-fire cartridges are shown at A, B, C, D; the case at C has a small cap containing the composition set on the bottom of case without anvil and has the metal pressed over on the cap to hold it in place; it was difficult to make a gas check with it. The case at D was an attempt to make an inside primer by a blank punched out like a star and then formed into a cup holding the anvil and cap with wings which were forced into place by stretching out the wings and securing them in the flange at C. 50 were fired without failure.

## PLATE VII

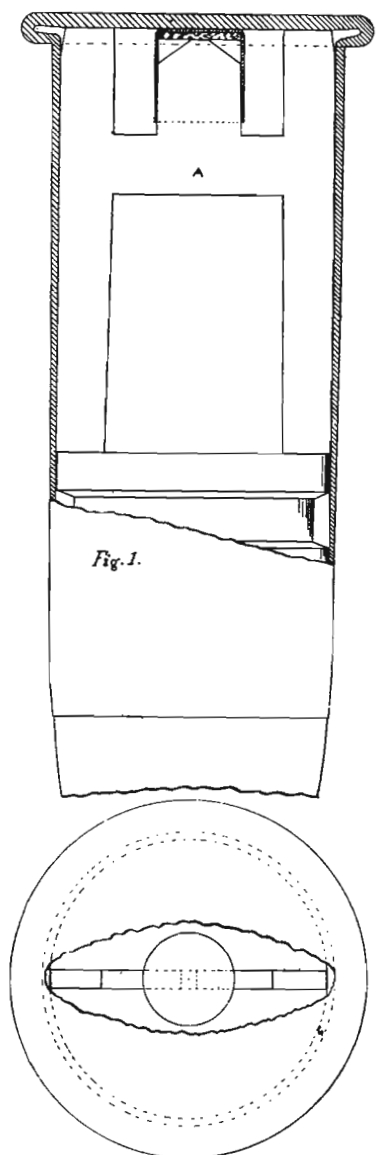
COL LAIDLEY'S  
PATENT  
1865.

EXPERIMENTAL.

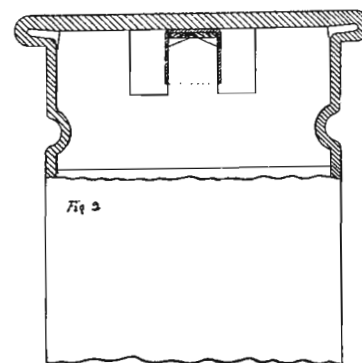

In this invention the cartridge is primed by means of an ordinary percussion cap supported by an anvil or stem resting against the base of ball, and kept in its central position by lateral projections or wings in contact with the sides of the cartridge case but not attached to either the case or cases.

Claims.—The combination of an anvil *A* with a cartridge case of a primed cartridge, the said anvil, not attached to the case, and receiving the percussion cap or priming on one end, the other end resting firmly against the projectile, and of such shape that when inserted it takes a central position and cannot be blown out of the case, which is tapered or contracted at its forward end; the whole as above described and for the purpose specified.

A number of the above were made for experimental purposes at the National Armory, Springfield, Mass. The anvil was punched from thin sheet iron, capped and inserted in the case which was prepared at the open end to allow its mouth elasticity in restoring the case to its original shape, and securing the anvil. A modification of this is shown at Fig. 2.

Patent Office Report, 1865.  
No. 51,326, J. I. S. Laidley, Ordnance Department; U. S. A.

NOVELTY.  
CENTRE PRIMED..

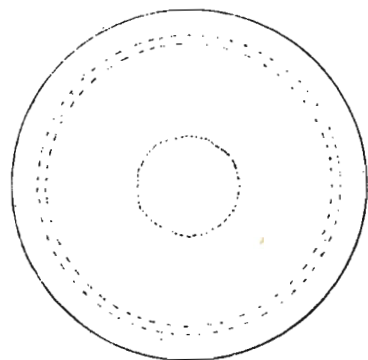
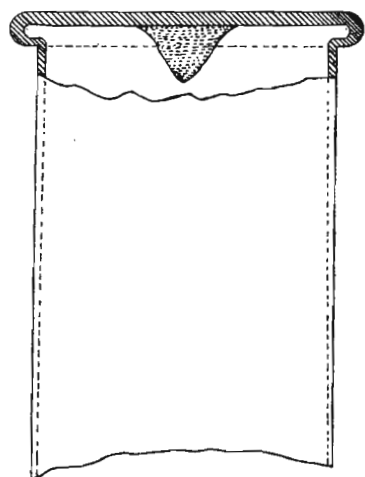

EXPERIMENTAL  
1866

Remarks.

Two Frenchmen appeared at this Arsenal about April, 1866, during the administration of Col. S. V. Benét, with a secret composition, proposing its use for centre priming. The composition in a wet state was deposited centrally on the bottom of the case, adhering sufficiently to the metal when dry and surrounded by compressed gunpowder to ignite with a blow. Twenty cartridges were fired with one failure (the composition was very sensitive) and great care was necessary in loading to avoid explosions. It would be liable to become detached in transportation and in service.

PLATE IX

SERVICE

BAR ANVIL

PLATE X.  
CARTRIDGE.

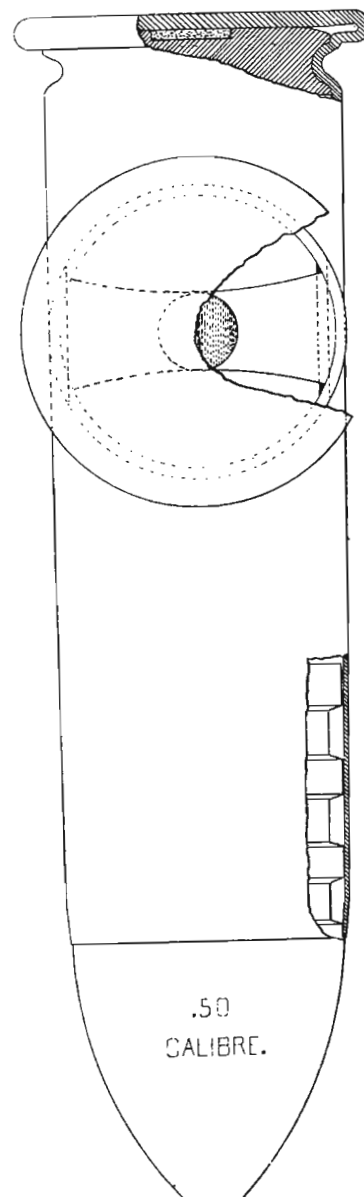

POWDER  
70 GR.

.50  
CALIBRE.

BALL  
450 GR.

1866

Manufactured at Frankfort Arsenal, Penna. between October, 1866  
and March, 1868.

GATLING

CARTRIDGE

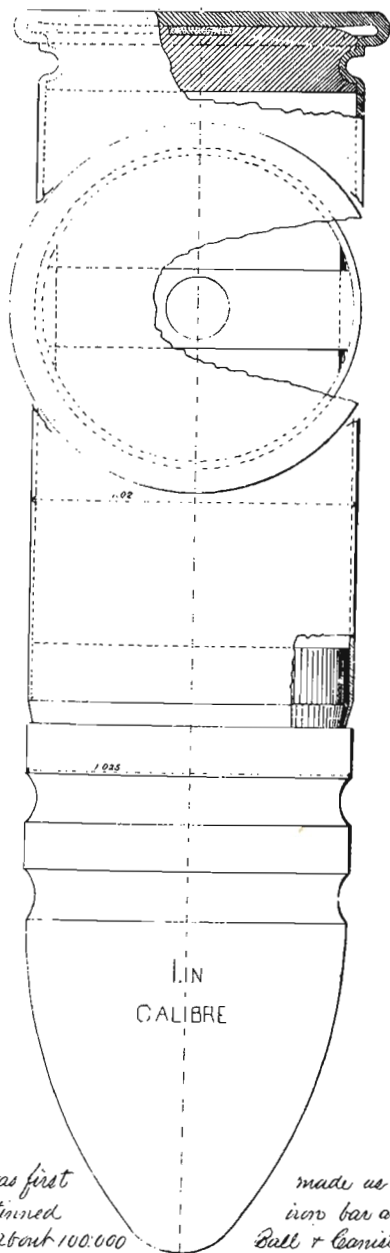
PLATE XI  
GUN.POWDER  
330 GRS.1 IN  
CALIBREBALL  
8. OZS.

Remarks.

This Cartridge was first  
1865. for experiment; a tinned  
in the manufacture of about 100,000  
anvil of tinned iron superseded the bar in 1868, of which a small number  
was made. Lately a copper disc was used by Col. Meadwell with entire  
success as an experiment.

made as a rim fire about Sept.  
iron bar anvil, Martins, was used.  
Ball + Canister in 1867. The cup

CANISTER

PLATE XII.

GATLING

GUN

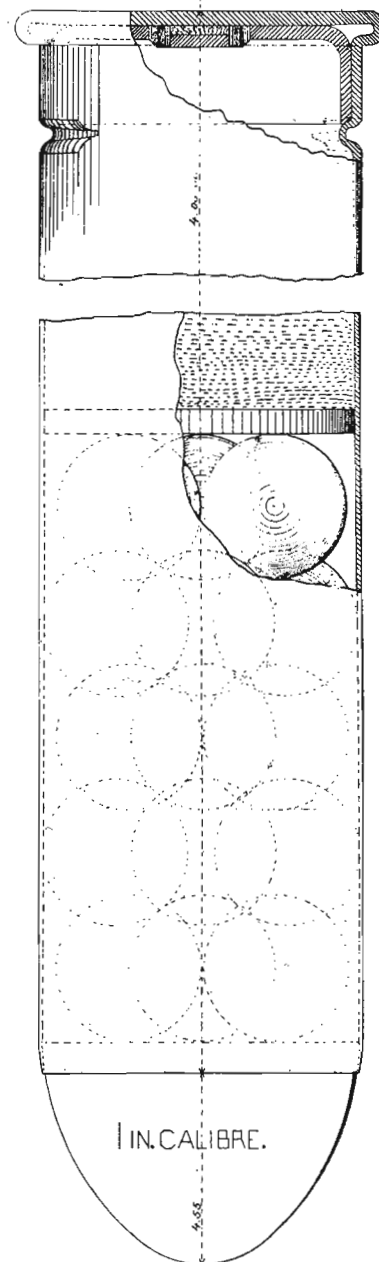
POWDER.  
330 GR.

1 IN. CALIBRE.

BALLS  
8. OZ.

Remarks - Made from copper .002 thick, diameter of case .62, length 4.05  
thickness of head .11, diameter of head .116, thickness of anvil metal .04,  
thickness of metal for copper disc .08, diameter of balls .25.

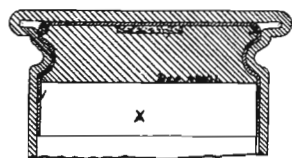

BENTON'S  
CUP-REINFORCE.

U.S. ARMORY,  
SPRINGFIELD, MASS.  
FRANKFORD ARSENAL,  
PA.  
1867.

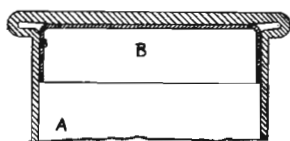

TIBBAL'S  
PATENT.  
1869.

The bar-anvil cartridge was first made at the National Armory, Springfield, Mass. in 1866, for experimental purposes, by S. K. Martin, (it was invented and submitted to Col. Denton in June, 1866,) who was employed at the Armory on cartridge work under the direction of Col. Denton. Its peculiarity at that time was its simplicity and mode of attaching the anvil to the case. It consisted of a copper case and a rigid tempered iron anvil recessed at the center to hold the percussion composition and grooved in the ends for crimping and securing it in place. Several millions were manufactured at this Arsenal from October, 1866 to March, 1868, when it was superseded by Col. Benet's cup-anvil cartridge.

Several objections were urged against the use of a bar-anvil: it was occasionally thrown into the barrel of the gun when firing; secondly, it was liable to be turned upside down; also crimping the case close under the head drew on the flange producing tension and causing occasional bursting. Col. Denton proposed and applied, in 1867, to the inside of the metallic case, Fig. X, a cup reinforce made from thin metal to protect or prevent the gases from reaching the fold; this remedied the last named objection but created another, occasional mis-fires from two thicknesses of metal at point of impact of the firing-pin; this may be overcome by opening the case to allow the firing-pin to act directly on the inside cup. (See gas-check experiments, Frankford, case No. 1.) It may be here remarked that so far as can be learned, the above application of a cup as a gas-check to a flanged metallic cartridge case was not specially claimed or patented until 1869, (2 years later than Benet's application of the cup reinforce,) which is as follows: Patent Report, 1869, No. 96607 to Mr. Debbala claims. The cup or reinforce B, when inserted within the flanged metallic case A, in such a manner as to cover and protect the flange, substantially as described.

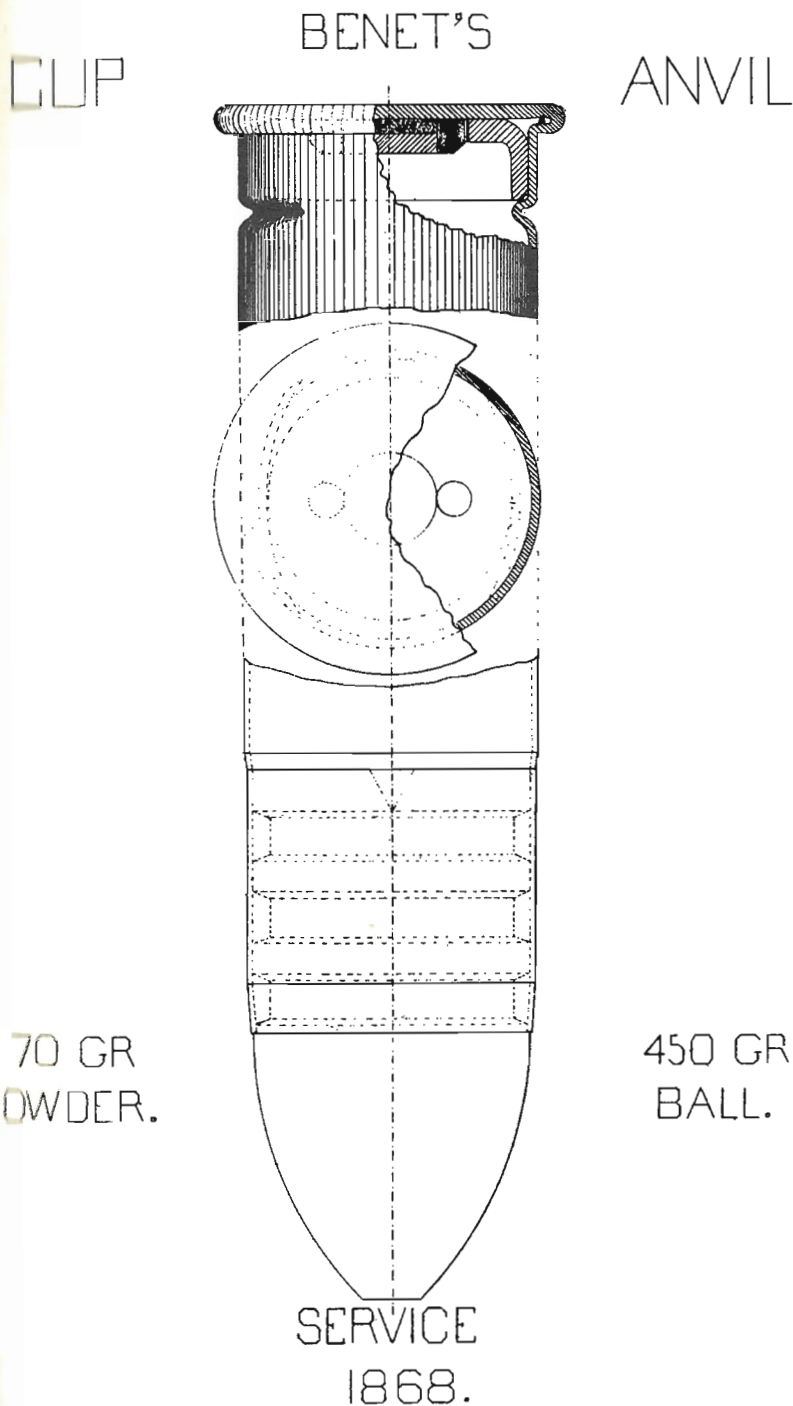

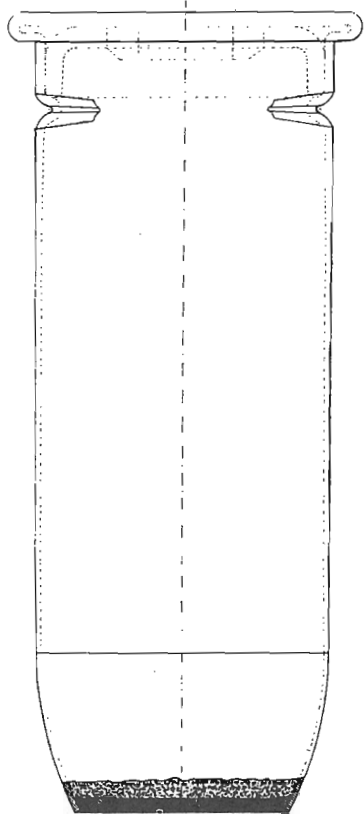
SERVICE  
BLANK CARTRIDGE70 GRS.  
POWDER  
1868*Remarks.*

The above service blank cartridge was adopted September, 1868. The end was tapered to assist its entrance into the gun chamber, also to have as small a mass of wax as possible. The wax is composed of 15 lbs. Seawax, 1 lb. Resin and 1 gallon North Carolina pine tar, melted together; this is applied cold by pressing on by hand. Cartridges have been made for the following arms: Navy Rifle, Spencer Rifle and Gatling gun and Coles, Remingtons and Smith & Wesson pistols. The metal used was from .022 to .025 in. thick.

## CENTRE BENET'S. PRIMED.

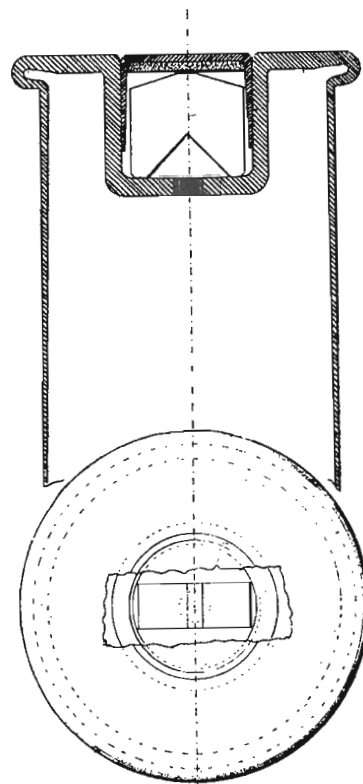
FRANKFORD  
EXPERIMENTAL. ARSENAL  
JAN 1866 APR*Remarks.*

The principal feature of this cartridge is the forming of the pocket of continuous piece of metal. It is believed to have been invented and successfully carried out at the Frankford Arsenal by Col. S. V. Smith, comd. in 1866. It is now one of the principal features of Benet's Cartridge, he having come to the Arsenal and obtained the necessary information, taking with him samples & sizes of tools and afterwards applying it to his cartridge, which previously had a separate cup inserted at the head.

## COL CRISPIN'S

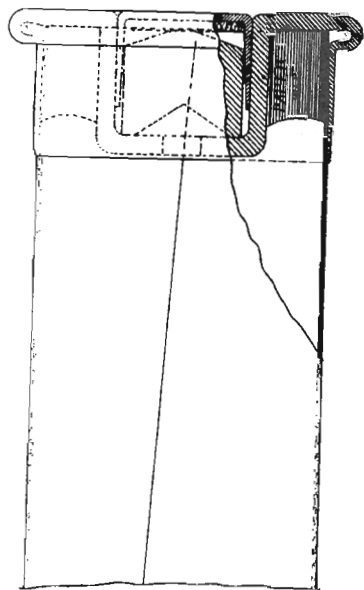

COMBINATION.  
PAPER  
AND  
METAL.  
WRAPPED. CASE.

*Remarks.*

In 1867 a number of these cartridges were made at this Arsenal for experiment on the plans of Col. Silas Crispin, Ordnance Dept. as follows. A strip of thin sheet brass about .002 thick was rolled by hand on a roller in connection with a sheet of paper, forming the case of three thicknesses of paper and two of metal, the paper covering the inside and outside of the case, having the metal between. The case was held to a brass head or cap by the friction of a paper wad. A number were fired extracting easily. This mode of attaching is not reliable it being affected by time and atmospheric changes in the loosening of the case from the head.

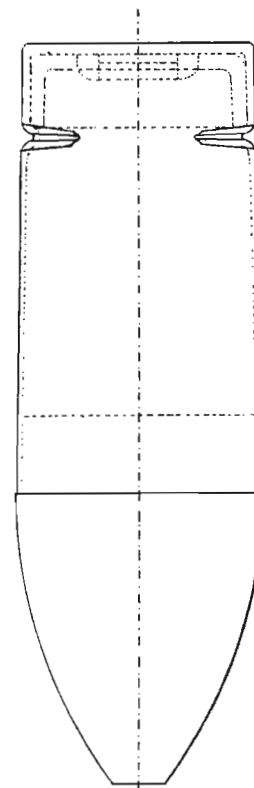
EXPERIMENTAL  
CARTRIDGE

FOR THE 1<sup>ST</sup> ALTERATION  
COLT'S PISTOL.  
NOV 1868

*Remarks.*

This cartridge was made as an experiment for use in the first alteration of Colt's army revolver. It was inserted into the chamber at the front end and held in place by the friction of the bullet and ignited at centre by a firing pin; the friction of the bullet was not at all times sufficient to insure ignition necessarily resulting in miss-fires. A cartridge made with a thin cap and outside priming is said to have worked well.

## MARTIN'S CARTRIDGE.

1ST PATENT. 1869.

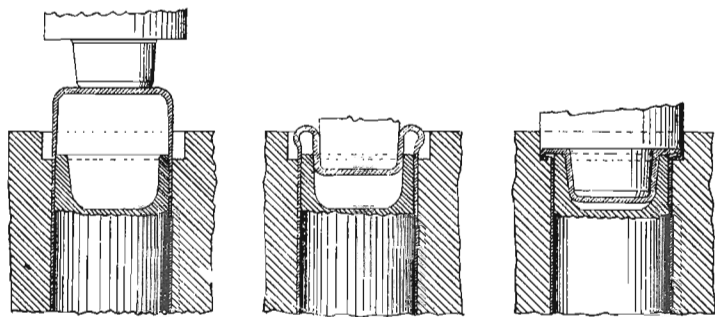

B

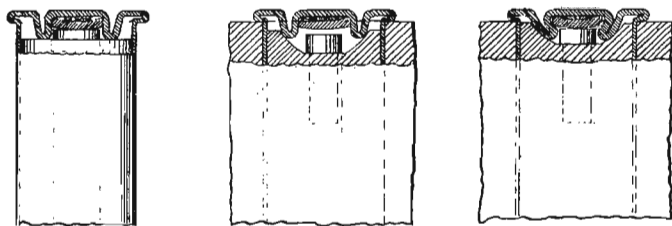
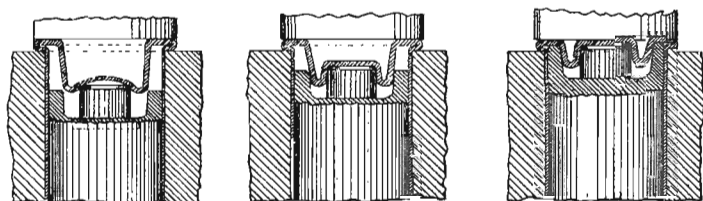

DETAILS

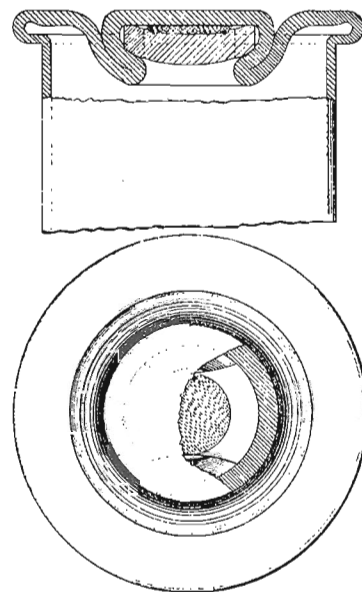

Patent No. 88,191. — Claim. — 1<sup>st</sup> An interior conical shaped pocket or receptacle containing the fulminate and anvil where the wall of said pocket is formed of two thicknesses of metal contiguous to each other substantially as described. 2<sup>d</sup> Turning over the upper part of the conical portion of the reinforcing cup upon and into the pocket or receptacle for the fulminate and anvil forming a gas check substantially as described. Invention patented and the use of it assigned to the United States by Edward Martin employed on experimental cartridge work at the National Armory, Springfield, Mass. Col. J. G. Borton, commanding, 1869. They were first made at the Armory for experimental purposes; during the year 1870 an additional fold under the head was added and patented by the inventor. A number of cartridges of this first patent were made at the Frankford Arsenal in 1871 for the Navy cartridge, Remington pistol and Colt's revolver, cal. .44 and .50. The peculiarity of the cartridge is the forming of an inside pocket from one continuous piece of metal and is performed at two operations. 1<sup>st</sup> as at A. 2<sup>d</sup> B.

MARTIN'S CARTRIDGE.  
SERVICE.  
2 ND PATENT 1870.  
MANUFACTURED  
FRANKFORD ARSENAL  
1871.

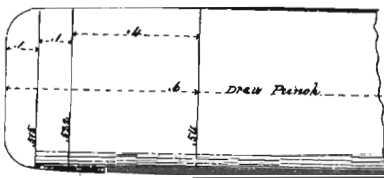
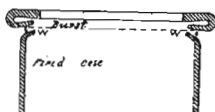
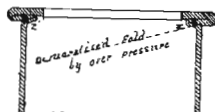
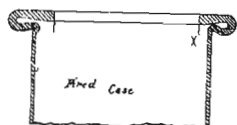
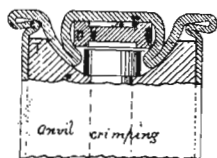
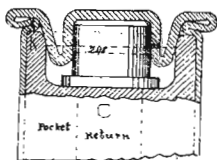
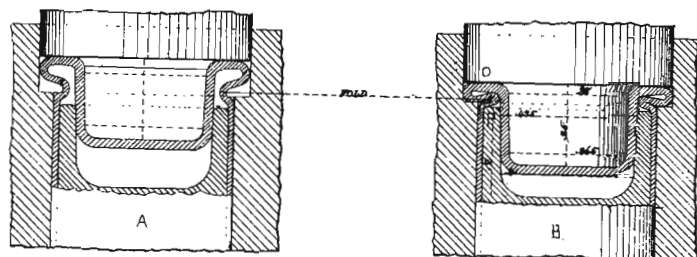

Patent No. 111,856-1870. — Claim-1<sup>st</sup> A metallic shell having the fold C made therein, making the shell of three distinct thicknesses at the juncture of the head with the cylindrical part as set forth.

Claim-2<sup>nd</sup> An annular fillet or corrugation upon the interior of the head of the shell in combination with fold C, all constructed substantially in the manner and for the purpose specified.

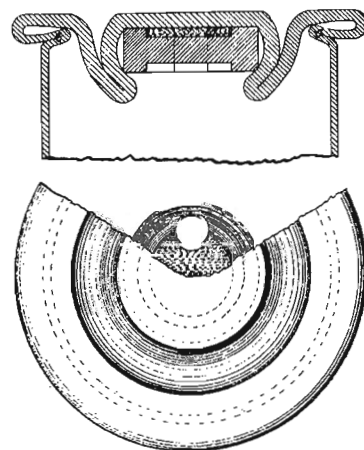

A large number of the Martin cartridges, cal. 50 were made at this Arsenal from May to Dec. 1871. The formation of the head-fold and pocket is shown at A, A, C, requiring two operations. The inventor used a single indented bar-anvil which was primed by hand-plates and was used until the machine primer was finished. A double indented bar-anvil, as shown at D, superseded the single bar in Sept. 1871, and in Oct. a double indented, disc-anvil, rimmed with one vent as at M, was suggested by Col. Sandwell and exclusively used thereafter. The hand priming caused a larger percentage of burnt composition in closing the pocket on the anvil than the double indented machine-primed bars. The disc had the advantage of a larger surface to resist the pressure in crimping or fastening the anvil, reducing the burning to a very small number as follows: Bars 1 to 5 in 1000; Disc 1 in 10,000. Burning the composition is an inherent defect of this cartridge, and cannot be prevented entirely, rendering an inspection of each case necessary. The peculiarity of the cartridge is the forming of an inside pocket to hold the anvil and the fold C of one continuous piece of metal. The object of the fold C is to give elasticity to the head. The ordinary plain folded head is rigid, and under strain, and may be more or less demoralized by the bending, according to the qualities of the metal. The fold C is supposed to give relief by yielding to the sudden force that would otherwise burst a more than ordinarily demoralized or defective plain folded head. A portion of the fold C is drawn out in the fired case. By increasing the force, the fold is entirely unwrapped, — see experiments with test specimens. All experiments show this a desideratum, obviating the necessity of reinforcing by an additional part, when the metal is not defective or the fold demoralized by impulsion. In manufacture the fold may be over-pressed at the heading, as it is formed between the punches O, P, and possibly in subsequent operations, as at R, T, presenting the appearance as at Z; and when fired occasionally bursting as at Y. This has occurred here and in service, the crimped bullet sometimes pulling the case off the head, dragging it into the rifled part, showing that it was separated before expansion of the case began. A result of so serious a character — attributable to defective metal and workmanship, although of a very limited extent; sometimes requiring the expenditure of several thousands rounds to produce a single such instance of bursting, — caused their manufacture at this Arsenal to be abandoned in December, 1871.

COL TREADWELL'S EXPERIMENTS.  
RELATIVE STRENGTH OF CARTRIDGE HEADS.  
FRANKFORD ARSENAL  
1871. 1872.

PLATE XXI

HYDROSTATIC PRESS.

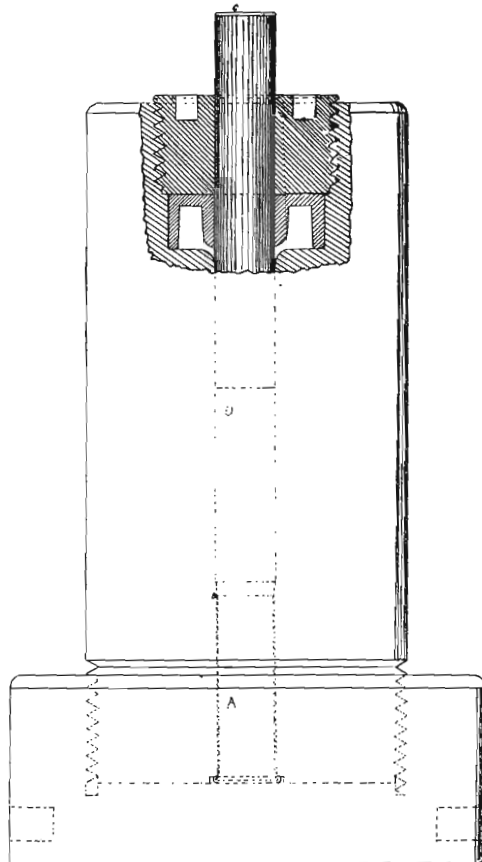

Remarks — As some means besides the gun was necessary to determine the relative strength of cartridge heads, this hydrostatic pressure arrangement was made to compare the cup arvil and Martin cartridges, and in a connection with a powder test to develop their relative strength. The chamber A represents that of the Springfield gun. The cartridge case was made thin and to fit at the end B tightly to make a water joint. After filling the space O with water, pressure was applied by compressed levers on the weighing machine to the end of the piston at C until the head gave way, the graduation on the lever indicating the pressure in lbs. to the area of piston, which is  $\frac{1}{4}$  of a square inch.

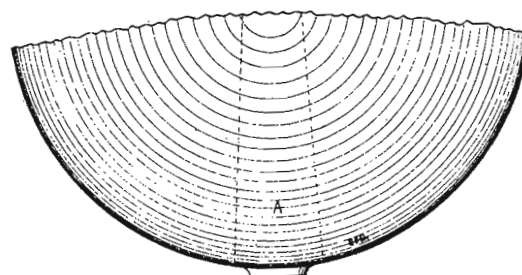
EPROUVETTE  
POWDER TEST.

Remarks — It is claimed that a constant weight as at A will at all times give uniform resistance of the same degree or intensity of force, all conditions being alike. An ordinary weight is not strong enough for the amount of force required to develop the latent strength of various cartridge heads, besides, the variations in weight and slugging of the ball will make the results more uncertain than by the above arrangement. The ball A, 28 lbs weight, is attached to the piston B and inserted into the barrel D, fitting with freedom at its end a gas check and was resting on the powder; the chamber O is like that of the Springfield gun; the cartridge is ignited from below by a firing pin and hammer; the weight A is thrown into the air and falls on soft ground, without damage, the number of grains of powder is increased, until it has burst the head of the cartridge, which is the recorded value or strength of the head.

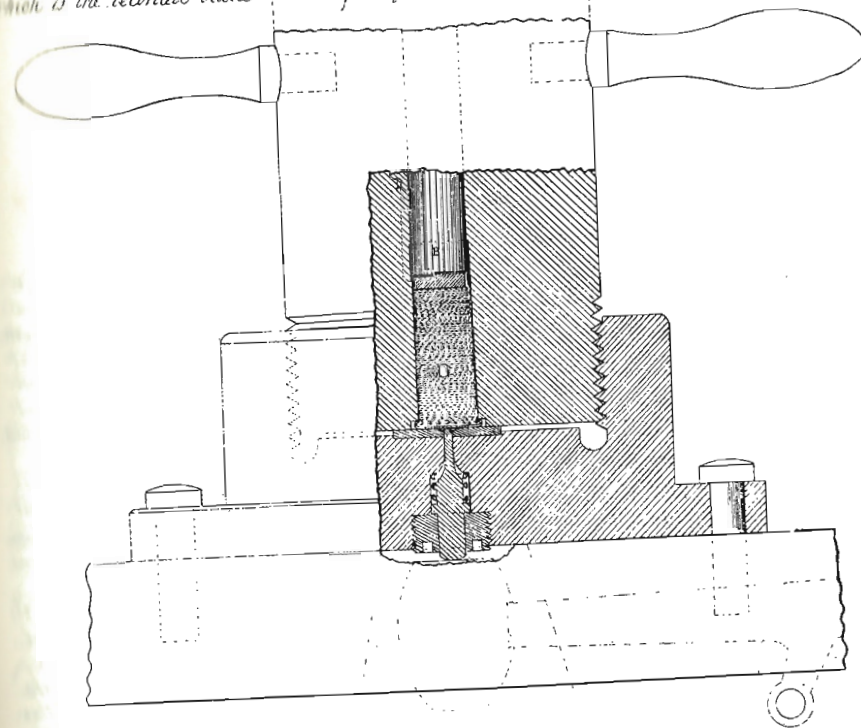

## COL. TREADWELL'S EXPERIMENTS.

PLATE J

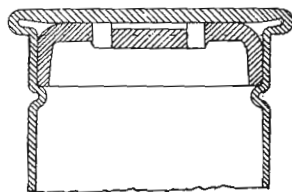
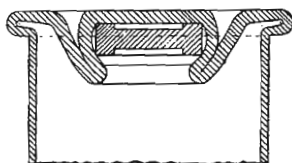
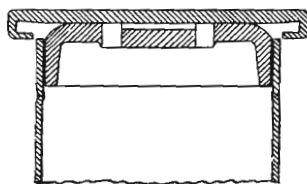
HYDROSTATIC  
TEST  
CLASS ICUP  
ANVIL

MARTIN

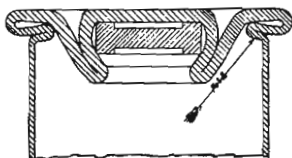
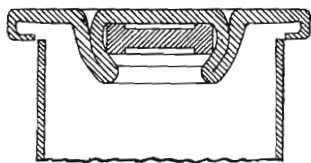
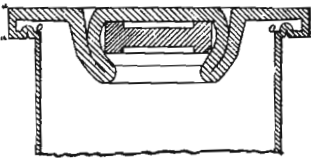
MARTIN  
WITH FOLD

## Remarks.

The Remington B.L. Rifle being introduced into service and having less leverage at the retracting point than the Springfield S.L. Rifle, objection was made to the cup-anvil cartridge on account of tightness of the powder case in extracting. It was claimed that the Martin cartridge, with fold, extracted easily without effort, and besides that the additional fold at the junction of the head with the cylindrical part of the case acted as a reinforce to the head. This was found to be erroneous idea, but it was demonstrated by experiment that it added greatly to the strength of the head by its elasticity.

For comparison the above cases were subjected to a pressure of 50,000 lbs per square inch. As the separated heads of the cup anvil, and Martin case, without fold, formed a complete check to the escape of the fluid, it could not be ascertained at what pressure they gave way; it is thought from other trials that it was about 25,000 lbs per square inch.

The metal in the Martin, with fold, spread to the limit of recess, taking its form with corners well defined as at a-a. A weight of 50 lbs was dropped 5 feet on the piston of the press to give the effect of a sudden blow; the Martin head, with fold, was considerably enlarged, the others not perceptibly affected. In the block used in the above experiments now converted into the test spruette, no other trial was made with static pressure, powder trials being deemed more natural and reliable.

## POWDER TEST.

PLATE XXVI.

CLASS I.

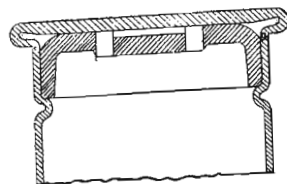
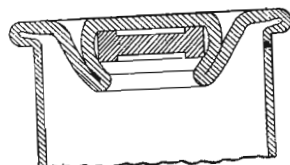
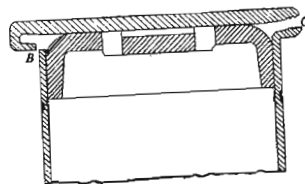
CUP  
ANVIL

MARTIN

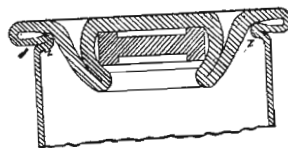
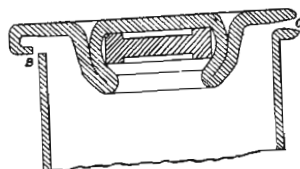
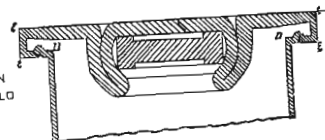
MARTIN  
WITH FOLD

Cartridges experimented with at this Arsenal in the Test Spruette may be divided into four classes. 1<sup>st</sup> Those whose flanges are folded and have a continuity with the case without additional parts as reinforcements. 2<sup>nd</sup> Same as the first with additional parts as a reinforcement. 3<sup>rd</sup> Those having the flange or base attached to the case. 4<sup>th</sup> Solid head. The above cartridges of the 1<sup>st</sup> class were tested in the Spruette. For test of the three other classes see experiments with Test Spruette. The value of the cup anvil and Martin without fold, varied according to the quality of metal and the thickness of cross section at a, ranging from 35 to 70 grains of powder, 90 per cent. going way at juncture of case and flange at B, and 10 per cent at C, where it is most demoralized in bending. At experimental firing with the Springfield gun all that burst, did so at C, averaging about 1 in 1000 and can only be attributed to an unseen defect in the metal. The Martin with fold could not be burst in the limits of the recess for head in chamber of spruette; 100 grains of rifle powder produced the effect as is shown at D. It is judged that from the result produced by hydrostatic test as at O, where 50,000 lbs per square inch was applied, that the pressure was greater in the powder test; the corners were sharply defined as at B, the fold Z was drawn out as at D proportionately according to the number of grains used; the same force that produced no swelling of head on the cup-anvil enlarged the Martin with fold 1/2 of an inch. Repeated trials with the spruette and the Springfield gun with experimental cartridges show that surplus metal at the head may be disadvantageously employed other than by the fold adding to the strength of a cartridge at base

COL TREADWELL'S EXPERIMENTS.  
POWDER TEST.  
CLASS I.

PLATE XXVII

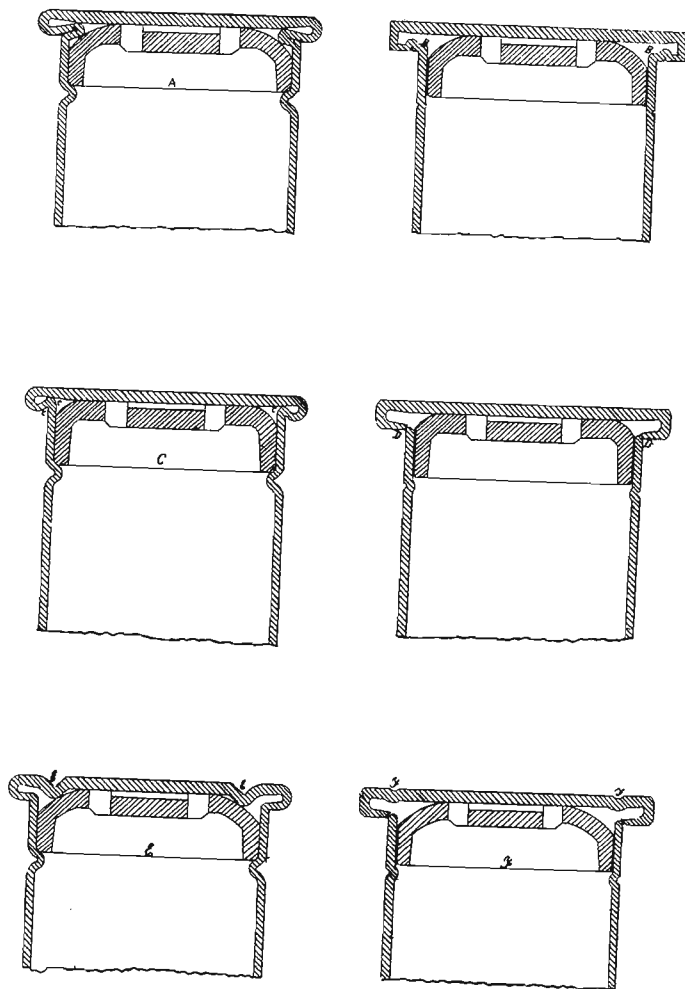
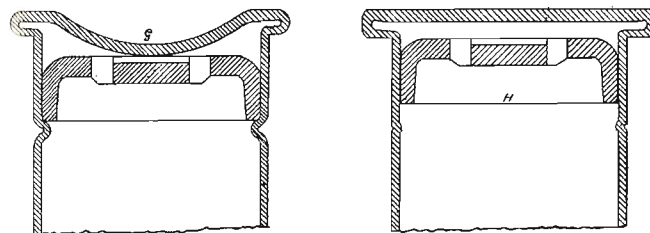
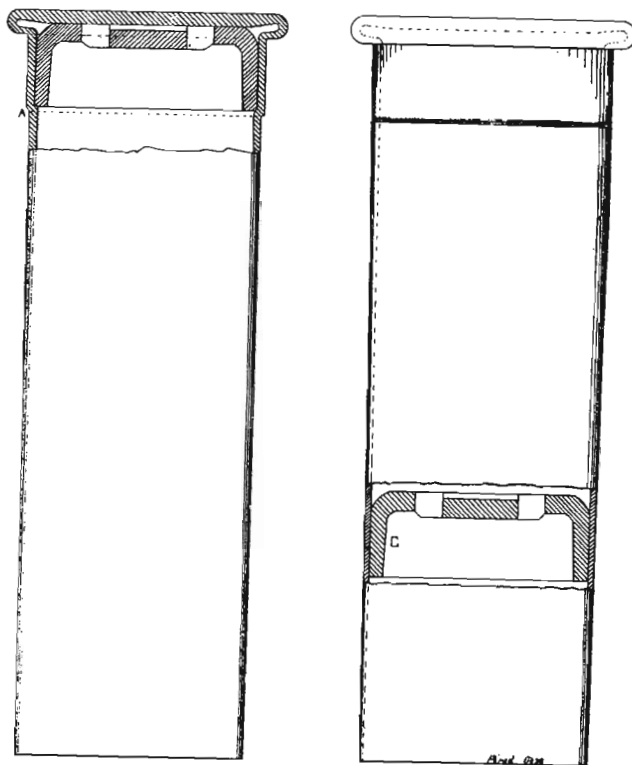

PLATE XXVIII.

CLASS I.



For experiment the Martin fold was applied to the cup-anvil case as at A; the eprauvette test showed the same result as this Martin case with fold; the fold was forced out as at B, filling the recess for head in the chamber of eprauvette without bursting; 160 grains of powder was used causing a pressure supposed to be about 7000 lbs per square inch. A modification of the fold is shown at C; it stood 80 grains separating the head from the body of case as at D. In manufacturing the modified fold as C applied to the cup-anvil case at C is not open to the same objections as that of the Martin nor is the metal affected by the slight bend at C as much as it is at the larger fold at A. The case after firing extracts easier than the ordinary cup-anvil, being more elastic; a number were made at this Arsenal and issued for service; the corrugated head as at E has a value, 70, the corrugation is forced out at firing as at F, relieving the otherwise rigid character of the plain head; the concave head as at G has a value like all the others with elastic devices in proportion to the amount of metal used in forming the elastic part; if there is sufficient metal it will stretch and fill up the recess for head in chamber without bursting as is the case with the concave head, Martin fold, &c. 160 grains powder was used forming the head as at H; as the plain head is light, under tension and so held by its form, the object of all these devices is for its relief, furnishing a susceptibility to the sudden force of gun powder which relieves its effects at the weak point, easing the extraction and obviating the necessity of inside reinforcement, while they afford considerable relief and are of value. It is doubtful if any substitute of this kind can be made that will prevent entirely the very small percentage of burst heads of the cup-anvil or folded case, which is believed to proceed from short or flawed metal that is not detected by the ordinary inspection, and might cause it to burst before the most elastic device could afford relief.

CLASS I.  
CUP ANVIL.

As the cup-anvil has a portion of its sides crimped or forced in to give support to the anvil it was supposed to cause unequal expansion at firing, producing the tightness at extraction complained of in the Remington gun. It was proposed to remedy this by dispensing with the crimp, as it only went part way around the case, and substitute a case reduced part way in size, say .015 in. - which supported the anvil all around its edges as at A. A number were fired in the Remington gun, compared with the Abnitor fold, it worked very well as to extraction with but an occasional tightness by the expansion of the case at the point that held the anvil in place as at A, in connection with a reaction of the force in several instances the anvil was driven towards the end as at C' wedging in the case. In manufacture the corners of the reducing die that formed the support of anvil, as at A, wore off rapidly and if not closely watched will make uncertain work, resulting in mis-fires; its value for strength is the same as the ordinary cup-anvil case.

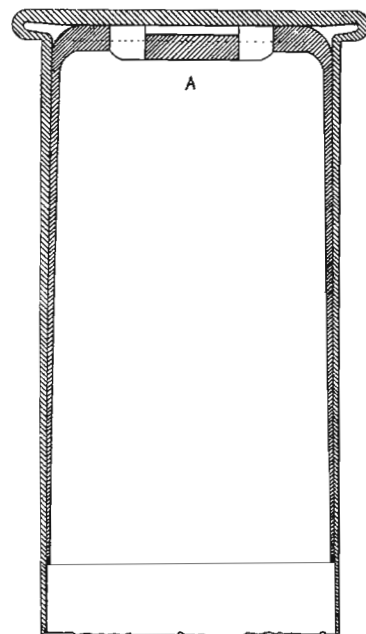
COL TREADWELL'S EXPERIMENTS.  
CUP ANVIL.  
CLASS I.

This experiment was made to determine the value of the cup anvil as a reinforce. It was claimed that it protected the fold and lessened the percentage of burst heads, notwithstanding the uniform swelling of and the occasional bursting of a head; the metal of anvil is made heavy, *cus*, for rigidity, to insure expansion, also the cylindrical part for stiffness to crimp against; the case when the anvil is fastened is about .02 thick. At firing the gas expands the case only, as it is thinner and more susceptible to the force than the anvil, the gas passed up between the case and anvil and in connection with the vent; acts as powerfully at the folds of flange as if no cup was present, holding the anvil in suspension, swelling the head and bursting defective cases. By cutting open a fired case the anvil is found covered with a thick coating of the residuum of powder and is of the same size as before firing. The case at A was made to determine what were the effects of the gas through the vents only, by preventing the gas from escaping up the sides; it was fired in the eprouvette in comparison with the ordinary cup-anvil case, all made from the same sheet of copper; both refused to burst at 40 grains of powder but gave way at 45 grains. The gas as with the fluid-static pressure-guns and maintains a volume of equal pressure through the vents and sides, proving that the cup anvil as used in service is only an anvil having no value as a reinforce.

## COL TREADWELL'S EXPERIMENTS.

## DISC ANVIL,

## CLASS I.

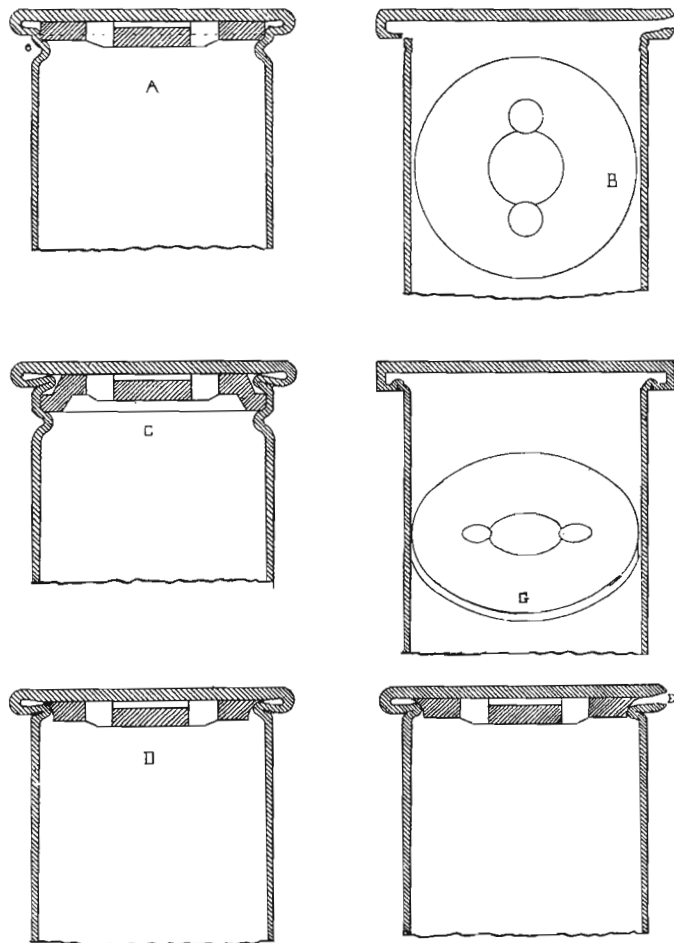

## DISC ANVIL

## CLASS I.

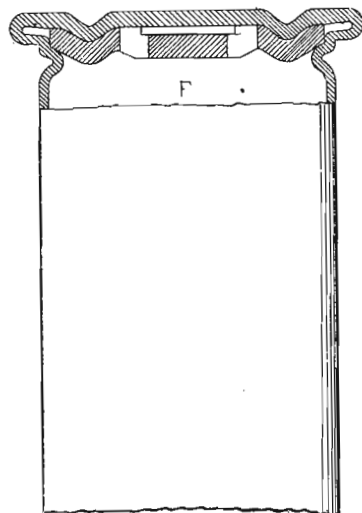

As the cup-anvil has no value as a reinforce it was thought the disc-anvil could be substituted on the score of economy, as it saved about  $\frac{1}{3}$  of metal and one operation, its rigidity and certainty of fire being equal to the cup-anvil. About 30,000 were made of this Anvil in September and October, 1870, for experimental firing and service. At the firing in the gun the expansion of the crimp caused the anvil to become loose and sometimes by the reaction of the gas was driven toward the end of the case, as at B, C; it could not get out as the case at the end was smaller than the disc; by the use of a heavy crimp and a gun chamber of minimum size it remained in its place with looseness. In manufacture the same tools and machinery were used as with the cup-anvil; preference is given to the cup-anvil as it is more easily handled in assembling and is not liable to be turned upside down.

The eprouvette test showed a less value than the cup-anvil, (135) for the same reason as was given in the case of the bar-anvil, namely, the crimping of the anvil over the flange, as at O, draws on the metal at head, causing a greater strain or tension. The application of the Martin fold to the disc-anvil, as at C, gave the same strength, (160) as with the Martin and cup-anvil; it could not be burst because of the elasticity of fold. The disc-anvil held by fold as at D is difficult to make, varying in value from 30 to 90, and always bursting at flange, as at E, while all the other kinds tried gave about 10 per cent only of bursting at that point. The corrugated anvil as at F has a value about the same as the corrugated cup-anvil which is greater than the plain head.

# CORLISS<sup>9</sup> FRONT IGNITION. EXPERIMENTAL.

CLASS I.

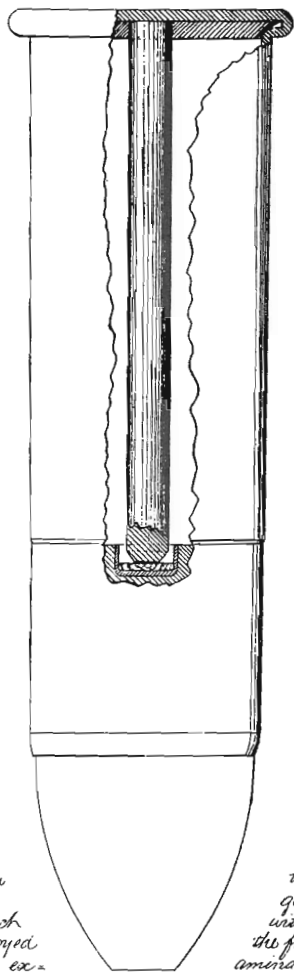
*Remarks.*

The Corliss Needle  
R. M. The needle was crimped into the flange of made to conform exactly per. The fulminate at the base of the bullet open to the In consequence of the extremity which the needle experiences from case the bullet was carefully the fulminate almost in contact starting the close gauge employed to explode in the gun. An ex- to have been forced into the bullet point 30 more cartridges were made at its apex like the notch of a watch; which it was thought would effectively explode the fulminate. Out of 18, 5 of them exploded. Average velocity of service 1326; of needle 1336 per second; mean variation in % service 0.3; needle 1.10. The was to be expected on needle cartridge gives a higher velocity, but in uniformity is much below the service. A target of 20 shots were attempted to be fired; 13 shots were secured in comparison with service. Practice at 500 yds. Mean absolute deviation, service 0.856; needle 2.169. Con- vected angle of sight, service 1.21.11; needle 1.21.11. Fouling from 111 shots, service 6 grs; needle 5 grs. Of the above 13 needle cartridges, 1 cartridge exploded, on 1<sup>st</sup> blow, 3 on 2<sup>nd</sup> blow, 6 on 3<sup>rd</sup> blow, 2 on 4<sup>th</sup> blow, 1 on 5<sup>th</sup> blow. Five needle cartridges also failed entirely to explode. The same want of uniformity that was exhibited by the velocities is here also in the mean absolute deviation. The fabrication of these cartridges was extremely troublesome and attended with no little danger of premature explosion.

Cartridge for Springfield P. L. attached at the base to a disc the case. The point was with that of the service firing held in a copper capsule on the rear and covered with tin foil limited longitudinal motion the indentation of the cartridge gauged in the loader to bring with the needle point. Notwith- the first 25 cartridges failed entirely amination the fulminate was found instead of being crushed by the needle with a needle flat pointed, and squared.

PLATE XXXI

# PRINCE'S EXPERIMENTAL

Class 1

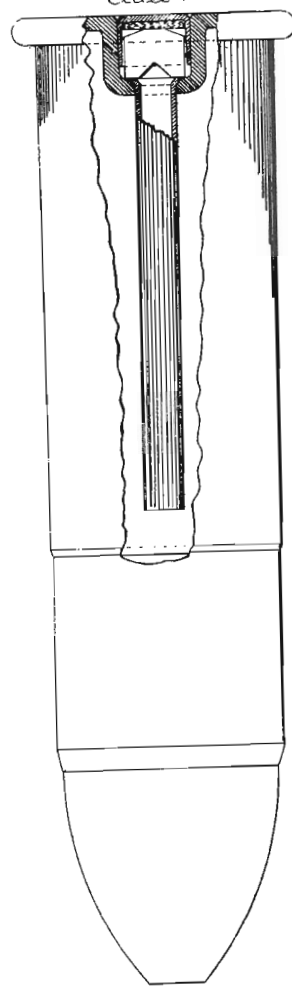
*Remarks.*

The above experimental front ignition tube cartridge, Frankford Arsenal, suggested by Capt. Prince, consists of a cup case, - a metal tube communicating with the front end of the cartridge reaching to near the head of the bullet - it is supposed to be primed with cap and anvil as shown in figure. No experiments have yet been made with this form of cartridge.

PLATE XXXIV.

## MILBANK'S PRIMER

AND  
RELOADER

PATENTED MAY 1870.

CLASS I.

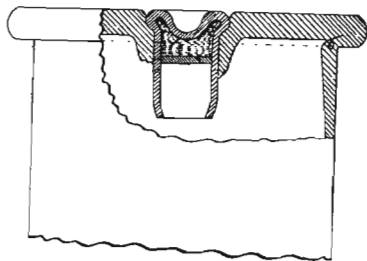

## Remarks.

A number of the above cartridges, Milbanks Patent, (May, 1870,) manufactured by the Winchester Repeating Arms Co., New Haven, Conn. labeled solid head, central fire, reloading cartridges, were tested at this Arsenal April, 1873.

The head is claimed to be a solid one, which is presumed to mean one folded closely as at O, similar to the Dutch Carbine cartridge. As it does not fulfil the conditions of a solid head it is rated under Class I. The metal of which the case is made is quite thick, about .05. The flanges have a greater variation in thickness than any other cartridge tested here, viz.: from .062 to .079 and are variable in thickness on the same flange at different points, showing bad work at an important point.

The primer is made somewhat like a rim-fire case, having a recess in the centre holding the priming, partly in the folded rim and at the bottom.

The composition is of a dark color resembling that in the Ely cap and is covered by a paper wad, the open end being slightly closed to facilitate its insertion into the hook of the case.

It was claimed to be superior in the following points.

1<sup>st</sup> Certainty of fire. 2<sup>d</sup> Non escape of gas at primer. 3<sup>d</sup> Superiority to mixture. 4<sup>th</sup> Facility in reloading.

Comparative performance of Winchester and service ammunition - object of trial - certainty of fire of both cartridges with the Springfield and Remington guns. Recar-pitulation - Winchester ammunition, Springfield gun - Fired in all 352 rounds with the following results: 70 required 2 blows to explode; 5 failed with 2 blows to explode. The primers were in a number of instances discolored by leaking gas. Winchester ammunition, Remington gun - Fired in all 250 rounds with the following results: 14 cartridges required 2 blows to explode. 7 cartridges failed to explode on 2 blows.

Service ammunition, Springfield gun - Fired in all 200 rounds with the following result: no failures of any kind except 1 case burst at flange.

Fired 100 rounds each of Winchester and service ammunition that were in water for five (5) days, with the following results, using a Springfield gun with both cartridges:-

Winchester Ammunition.

70% required two blows.  
11% hung fire, 2 on 1<sup>st</sup> blow + 9 on 2<sup>d</sup> blow.  
3 cartridges failed on 2<sup>d</sup> blow.

Service Ammunition.

No failure of any kind, all exploded promptly on 1<sup>st</sup> blow.

## COL TREADWELL'S EXPERIMENTS.

CLASS 2  
REINFORCEMENTS

CUP ANVIL.

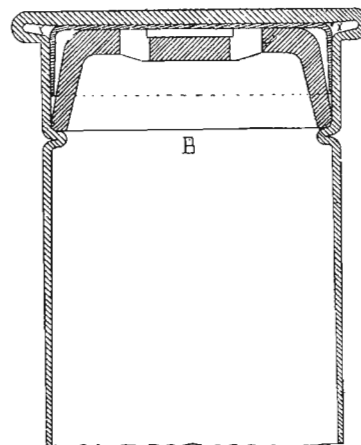
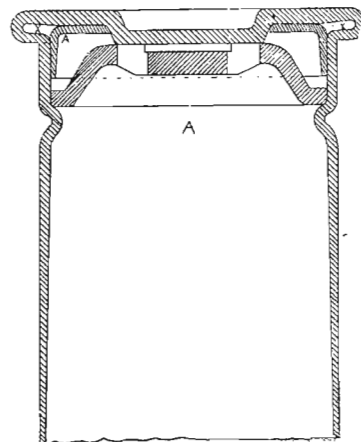

GAS CHECKS  
REINFORCEMENTS.

CLASS 2.

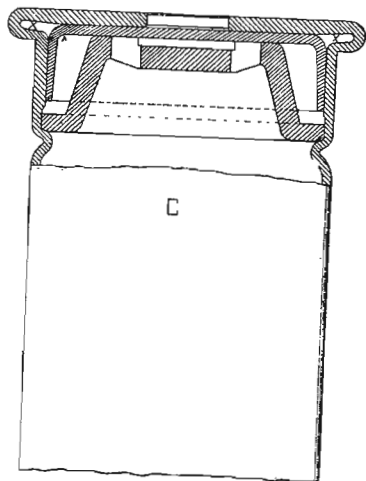

Class 2 consists of cartridges having the flange or head folded on from continuous metal, with additional parts as reinforcements or gas checks, which are intended to prevent the gas from reaching the annular space formed by the bond of metal at flange, as at X. All experience shows the necessity of protecting this weak point of a folded head cartridge, where it is desired to have a case that will at all times prevent the escape of gas from the base, from bursting caused by defective metal or workmanship. Various kinds of material have been tried, such as copper, brass, lead solder, graphite and paper. The essentials of an effectual reinforce or gas check are, - 1<sup>st</sup> that it must not flow into the annular space at bond transmitting the gas pressure as by the use of soft material as lead, solder, graphite, wax, &c. 2<sup>d</sup> it must be of such form and construction as will be acted on and expanded quicker than its case or covering. 3<sup>d</sup> it is required to fit tightly against this part to be protected without space to prevent the formation of a volume of gas behind it. The best form is that of a cup, as at A, which is used extensively in hydraulic pumps. Application of the cup, (Centers reinforce) as a gas check to the cup-anvil cartridge has been attempted for experiment, as at B, B, & C. B and C were fired in the Springfield gun and worked well, preventing the gas from reaching the fold; the two thicknesses of metal at B is objectionable, causing mis-fires; the open case C, a good feature in a cartridge, allowing the firing pin to act directly on the reinforcing cup without cutting through. About 25 were fired with good results.

## COL TREADWELL'S EXPERIMENTS.

GAS CHECKS  
REINFORCEMENTS.

CLASS 2.

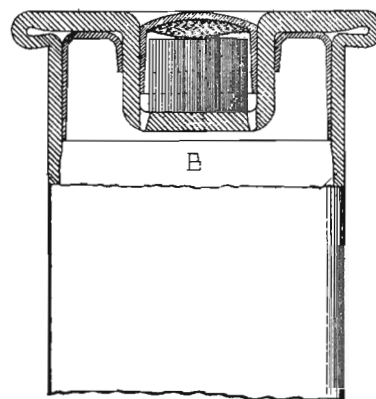
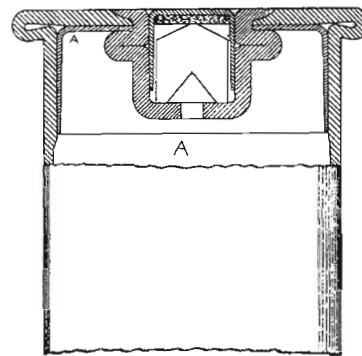

The feature of the Frankford experimental case, Fig. A, is the manner of holding the gas check cup; the priming cup or pocket is used as a rivet to secure its parts together; the pocket or cup as a rivet is used by the English and others to hold the body and case together and is not novel. 2<sup>d</sup> Cartridges made from brass were fired in a Remington gun showing no signs of swelled head and extracting easily - Aug. 1872. 3<sup>d</sup> Entirely some of the above features have appeared in a patent to Hallbank, No. 131,017, Sept. 1872, as follows: - The combination, with a head and case, of a cup serving as a priming cup as well as a rivet for securing or aiding in holding the parts together. Also see attached heads, Class 3.

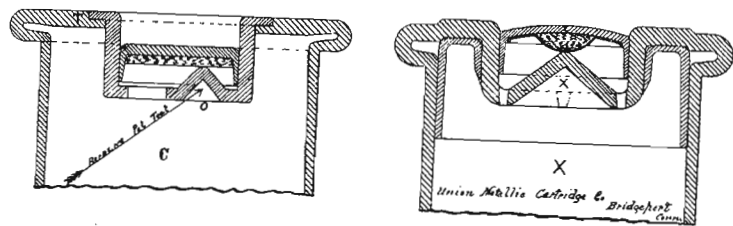

The Frankford experimental case for reloading. Fig. B, has its peculiarity in the use of an anvil of one dimension, a cube or sphere, the object of which is to secure, when dropped or fed by plates or machinery, a right position in the pocket. It was thought that spheres should be made like shot by dropping; the metal, or alloy must be as hard as soft brass to insure ignition of the cap; a few for experiment were cast from type metal. 20 were fired with one failure, the alloy was too soft and difficult to cast into a mould. The same results were obtained from a lot furnished by Mr. Sparks, shot manufacturer, Philada. It is doubtful if an alloy hard enough to insure ignition can be cast or dropped; the cube is easily made of brass .12 on the edge by punching in a double-action press; it presents a flat surface to the composition but is not so sensitive as a pointed anvil. The cap is disiguely made spherical on the crown so as to contain a small portion of priming and is deposited in the cap as to be thickest in the centre, occupying all the concavity to the limit of cylinder; by the use of moist priming made sensitive with glass and a tin foil varnished on the under side and pressed on tightly which adheres to the composition and metal of the cap when dry, a sure and effective cap was made. For further security it may be re-varnished on the top of the tin foil; diameter of pocket and cap .22; depth of pocket .19; thickness of metal .036. As this is brass it is used as a reloader, the extraction and insertion of a cap is as quickly done as in that of the Berdan.

The case, Fig. C, having the anvil or test thrown up from the bottom of cap as at O in combination with a primer or cap is known as the Berdan anvil. Patent Reports, 1866, No. 53,338. After seeing the pocket formed of continuous metal, Comé, at this Journal, 1866, he very quietly applied his test anvil to it, soon however changing the test or projection from side as at O to the centre, Fig. X, forming in connection with the Hobbs primer and an interior gas check cap with brass cover a very reliable cartridge. A large number of these cartridges have been made for the Russian Government by whom it is used as a reloader. The throwing up of a portion of the pocket to form the test or anvil is quite ingenious, but the first method adopted as shown at O, Fig. C, is believed to be of English origin and has a very different value from the present one used in Fig. X as an effective anvil, and the former cannot be well used as a reloader. The cap at Z is known as the Hobbs primer from his patent dated Sept. 11, 1869, No. 71,703; - claim, a percussion for guns enclosed between varnished surfaces. Its peculiarity is the use of a small quantity of composition rammed in centre and held in place by a varnished tin foil covering, which is attached to the metal of crown by varnish. The cap is of brass and is coated with varnish on the bottom to prevent amalgamation, making altogether a very good primer. About 2000 of the Berdan centre-fire cartridges have been used here in experimental firing and it is thought to be a first class cartridge. An experiment test - the cap, which is thin metal cut by the firing pin through, - with 70 grs. as its flange is well protected by a gas-check annular cap, no bursting in the head is liable to take place.

## COL TREADWELL'S EXPERIMENTS.

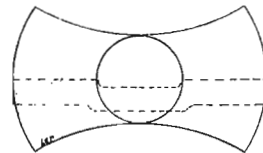
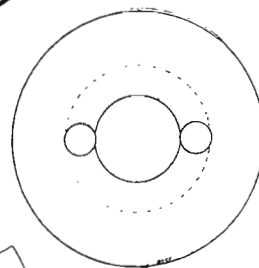
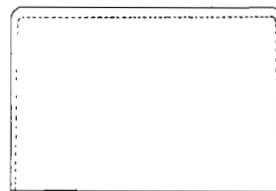
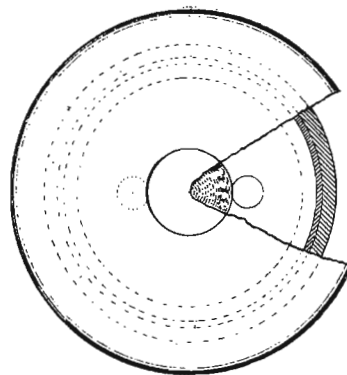
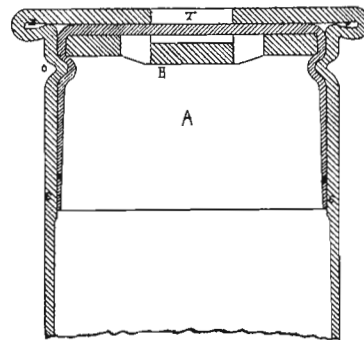
GAS CHECKS  
REINFORCEMENTS.  
CLASS 2.

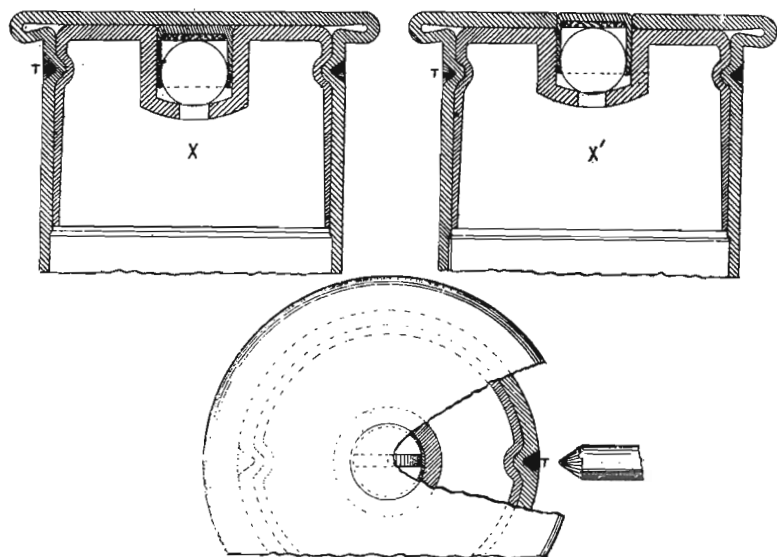
GAS CHECKS  
CLASS 2.

As it is desired to have a service cartridge that contains the following necessary requirements, viz:— 1<sup>st</sup> Certainty of fire. 2<sup>nd</sup> Not liable to burst at head. 3<sup>rd</sup> Extracted free. 4<sup>th</sup> Safety in handling and transportation. 5<sup>th</sup> Water proof. 6<sup>th</sup> No deterioration from chemical action, climate or temperature. 7<sup>th</sup> Uniformity and economy in manufacture.

The case, Fig. 1, known as the Frankford case No. 1, was made to fulfil comparatively the above conditions. It is made from brass with a cup gas check and anvil, a combination of an open case—(a hole in centre of outside case large enough, say .15 in., to allow the direct action of the firing pin on the inside cup)—with a cup gas check containing the anvil, the same as Berdan's cup reinforce case, improved by opening the case as at T<sup>1</sup> and is so recorded for the United States, the igniting point as at B laying to the rear of the termination of the sides of cup, gives the best opportunity to make a complete gas check. The sides of case should be about .025 in. thick, as at C, while the thickness of sides of inside cup should be under .01 of an inch, say about .0075 or .008, as at D. The head of such thickness and diameter as to band symmetrically. The principal to be attended to in manufacture are the security of the anvil and the certainty of action of the cup as a gas-check. The anvil may be fastened into the cup first and then the cup forced tightly into the case and secured by crimping or knurling or by placing the cup into case first and fastening the anvil and cup to case at the same time as at O; 50 were fired in the Springfield gun satisfactorily, (12000 lbs pressure per sq in.) 90 grains of powder was used in the spruvelite without bursting, pressure about 30,000 lbs per sq in. The only question to be determined by larger trials is the liability of the cup to cut-through at the opening in case at head; so far no bad results appear. The case as at X, in zinc priming stood 160 grains in spruvelite without bursting. The fastening in of the cup as at T<sup>1</sup> is done with a round point and is sufficient to hold against the blow. The case as at X' outside priming gave good results also.

The idea of an open case suggested itself at the objection raised by Col. Denton: the thickness of metal near at first by Col. Denton in the bar-anvil cartridge. (See page 5. Ordnance Memoranda No. 8 of 1870.)

## PRIMING.

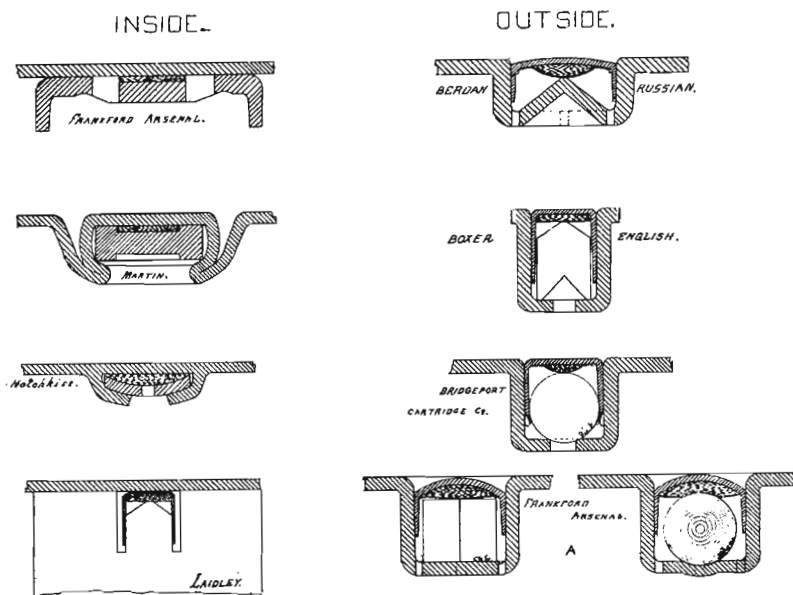

The above modes of priming have been used for experimental firing at different times at this Arsenal. The last feature of outside priming appears at A, (Frankford Arsenal, Jan'y, 1872,) in the use of an anvil of one dimension, spherical or cubical in form. When dropped casually into pocket it will take a right position and can be fed by plates or machinery. The Berdan anvil formed from continuous metal of the case without attachment and Berdan's cup is considered the best for outside priming. It is not, as far as known applied to diameters of heads below .215. It is patented and used extensively by the Russians as a reload. Inside priming, as it is practiced at this Arsenal, in its wet state, by the use of automatic machinery, is supposed to possess advantages over outside priming, 1<sup>st</sup> In its safety. 2<sup>nd</sup> Simplicity and freedom from accident in manufacture by the use of wet composition. 3<sup>rd</sup> No liability of the priming becoming loosened, detached or otherwise affected by rough usage in transportation and service, as it is held tightly in a receptacle without intervening space as at O. The Berdan and service cases were each placed under a drop to test their relative sensitiveness, the distance of the fall of weight by which they were exploded was as 2 to 5, varying according to the thickness of metal and sensitiveness of the composition. A flat pin will explode an outside primed cartridge having a pointed anvil with a light blow, while it takes a heavier blow concentrated on the acute point of firing pin to insure ignition in the service case. Both kinds, the Berdan and Frankford cube anvil, were subjected to a jolting and tumbling of the composition, resulting in detaching the tin foil and composition in the Berdan caps; the Frankford primer, cube anvil, tin foil covering, moist composition was not seriously affected, as the flatness of the anvil held the composition, there being little intervening space.

## COL TREADWELL'S EXPERIMENTS.

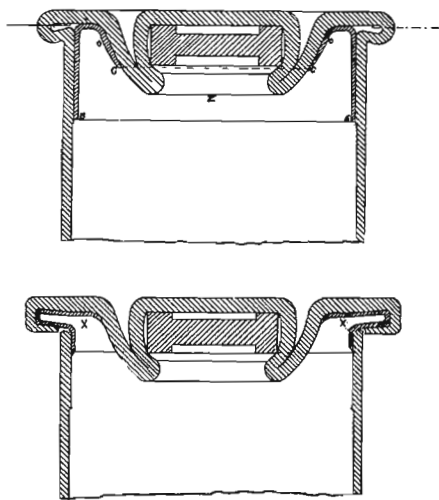
GAS CHECK  
REINFORCEMENTS  
CLASS 2.

A gas check reinforce cup was applied to the Martin case without fold, for experimental firing, the annul pocket occupying so large a space together with its walls makes it of more difficult application than Frankford case No. 1, besides it has two termination bands C which are required to lay close against the sides and walls. The Martin case when made from copper, which is less rigid than brass, requires the cup to be made from thin metal about .01 in thick and forced into the case tightly taking the form as at O; when the cup is correctly placed it makes a good check as will be seen at X, when the head is removed from the body of the case by the pressure of gas in the chamber the copper case gave way at 60 grs, the brass case at 70 grs.

Remove the top of flange by cutting it through cross-wise as is shown by the red ink lines; if no residue of the powder is seen it is proof of the work of the cup as a gas check; sometimes a slight discoloration from the gas appears which is of very little or no effect at the fold and is incidental to the manufacture; at the start of the ignition especially when the gas check lays too near to the front of the cup as at Z, the pressure being slight the gas escapes through any little irregularity caused by the manufacture but is closed as the pressure is increased.

## COL TREADWELL'S EXPERIMENTS.

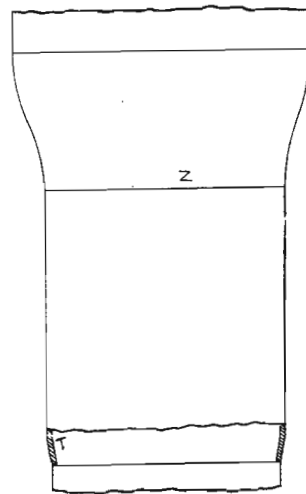
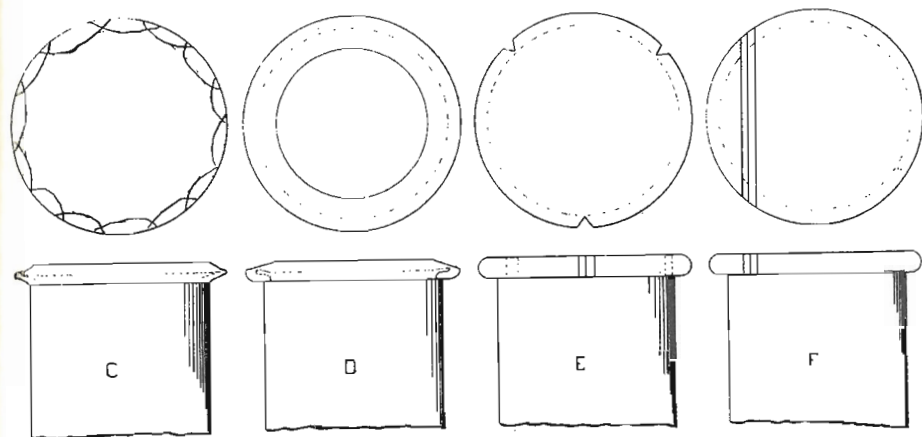
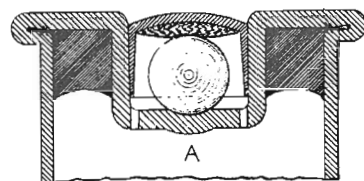
GAS CHECK  
REINFORCEMENTS.  
CLASS 2.

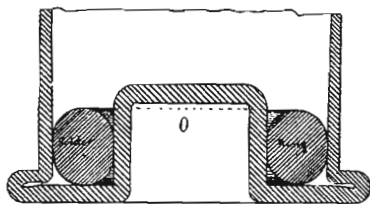

That class of cartridge cases, Fig. A, having a sufficient annular space formed by the pocket or priming cup affords a good opportunity for reinforcing the head by an annular metal cup, ring of solder, or wads of lead, graphite, paper pulp, gum, cloth, wax, &c. Solder, by its intimate cohesion to the metal, makes a more complete gas check than any other material known except perhaps the metallic annular cup; its usefulness is, however, limited by the amount of heat and pressure generated by the cartridge; if it is fused or too much softened, the pressure of the powder gas acts on it as a fluid rendering it useless; it was thought to be of some value and was used in attaching a cup head (a small cup with a folded head) to the wrapped metal case manufactured for experiment and test in service in November, 1871, and was deemed preferable to the riveted head or other modes of attachment. For experiment it was also applied to cartridge cases, Fig. B, reduced to .45 and .42 calibres, the pressure on the flange of such a case, (bottle shaped, reduced from 5/16 diameter of body to 1/2 of bullet at the end) with a heavy bullet crimped, Fig. Z, at T, it was supposed, would be considerably greater than with the ordinary conical case; ten cartridges of brass, .45 calibre, 80 grs powder, 400 grs. bullet, were fired extracting very easy with no swelling of their heads; ten more were also fired from .42 calibre gun, 50 grs. powder and 370 grs. bullet, they likewise extracted with ease, the heads slightly swollen; three other .42 calibre, 80 grs. powder and 380 grs. bullet, (made designedly heavy to increase pressure) were fired, 1 burst; 3 more, without solder, were fired with same charge of powder and 370 grs. bullet, all the kinds blown clean off. Cases, Figs. C, D, E and F, with solder, were punched, then turned and cut nearly through the brass with a file, 3 of each were fired, only one, as at C, burst, using ordinary charge and bullet. Several Remington cases with and without solder, a smaller quantity for the unit of capacity around the cup, were fired the heads were blown clean off; the brass cases were more stoutly made than the ordinary copper ones and with a small space at X which makes it more difficult for the solder to flow, under gas pressure, the thickness of the solder should be not less than 1/16, as the effect of pressure is in proportion to its depth; in the spruette with 28 lb ball, 60 grs of powder were used without bursting the head of case; but with 70 grs. the solder melted bursting the head. So far as can be learned by repeated trials of the service wrapped metal case the solder was not affected by the heat and pressure generated by 70-grs. powder and 450 grs. bullet in .50 calibre musket so as to transmit (during the flight of ball and maximum pressure) its sufficient force to burst an ordinarily deformed or cracked head, which, with out solder, would have burst. About 2000 of the service case, Fig. A, with a cubical invul were made for experiment and service, a ring of solder, Fig. O, being used in connection with a drop of muriatic acid and fused by placing the case on a hot plate, the solder forming a solid head and finding its way through any crack and appearing on the outside, thus detecting any defect of metal that could not otherwise have been noticed. A number of such cracked heads were fired showing no leakage; the balance were rejected as not suitable for issue but were fired in a .50 calibre Gatling gun. The acid and heat seem to permeate the brass, acting on the zinc and discoloring the case. This may be removed by pickling or dipping in dilute nitric acid and washing. The case being of brass can be used as a revolver at least ten times, as per trial.

## COL TREADWELL'S EXPERIMENTS ATTACHED HEADS CLASS 3

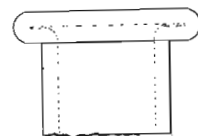
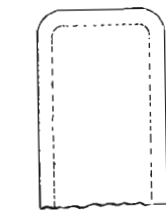
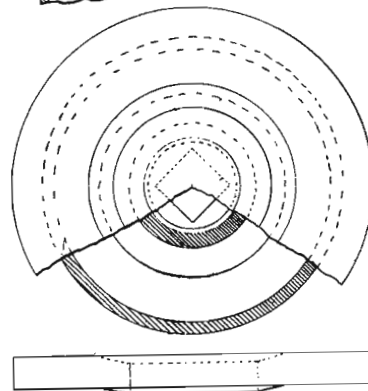
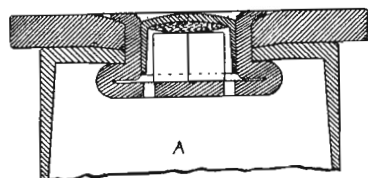

## CLASS 3.

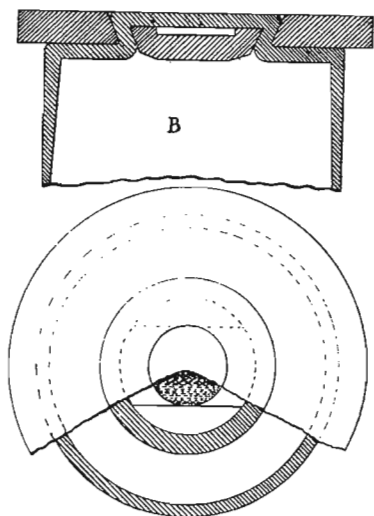

Class 3 consists of cartridge cases that have a flange or head attached to their base. They are principally used when the material composing the case does not admit the formation of a folded flange, as the Roodman and Crispin, Bocar and other cases made of paper or wrapped metal or combination of them. The head is generally secured to case by a rivet cup; solder is also used to fasten it as the Maynard, Frankfort case (Kendall & Crispin) with a folded head or cup. See wrapped metal case.

The Frankfort case, Fig. A, was a suggestion arising out of the consideration of the cost and manufacture of wrapped metal cartridges at this Arsenal, November, 1871. It was thought that a brass case without a folded head could be drawn thin, and made up with fewer operations and less cost than the wrapped metal, and have a strong base, easy of extraction, besides being water proof. For experiment a number were made and fired with 80 grs. Rifle powder and 300 grs. bullet in a .40 calibre 18 inch twist rifle; the extraction was very easy, the head was a little loose sideways caused by the expansion of case; two cases were reloaded and fired, extracting with freedom; the test was a severe one, proving its strength of base. In experimental firing several Meuser cases, with cal. .40 rifle, cut through at the extractor seat; for similar experiment it was necessary to reinforce the cup, anvil case, using 80 grs. Meuser powder, by an additional thin cup, as made at Springfield. A late patent dated Sept. 3, 1872, to Hailbank, claims the principal feature of the case, Fig. B, as follows: the combination of the head and case and the cup serving as a pinning cup, as well as a rivet for securing or aiding in holding said parts together. The cup, Fig. B, is presented as a novel mode of attaching the head, Army, 1871; the head is forced on and cuts in holding the anvil. No trials of it have as yet been made.

A cartridge case that has the end closed on the ball and crimped, when fired, first makes an effort to pull off the head; if this is detached the case is sometimes drawn slightly in the chamber and even into the rifling. This accident which is of a very serious nature and temporarily disabling the arm, has occurred in some cartridges of peculiar construction. Attached heads may, from carelessness in manufacture & inspection, become detached in firing or in extracting if the case sticks too hard. Judging from experience it would seem that such an accident is hardly possible with the plain, folded head, which when it bursts only faintly opens at the flange, leaving its full thickness to insure extraction.

COL TREADWELL'S EXPERIMENTS  
WRAPPED-METAL  
CARTRIDGE.

CLASS 3.

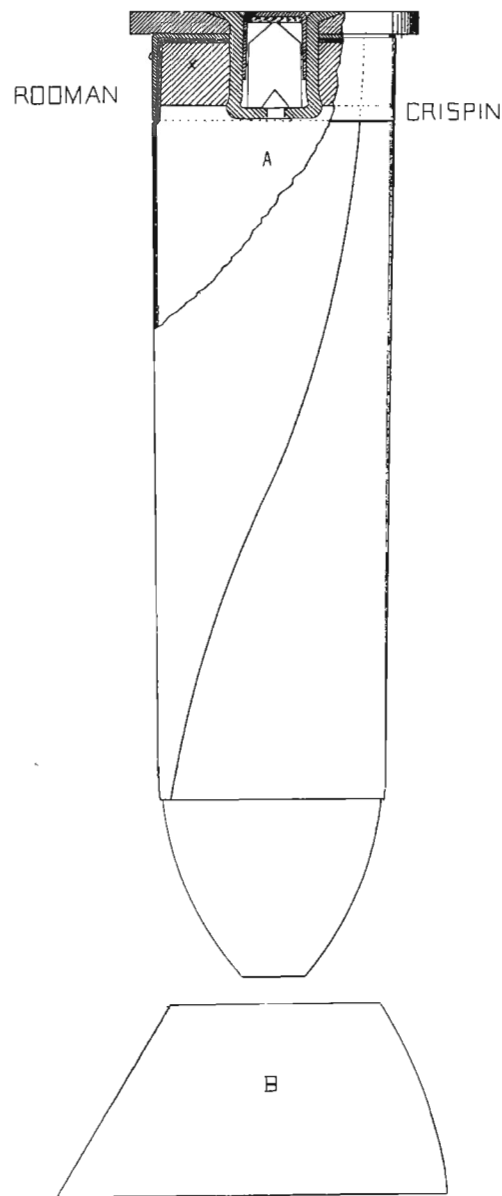

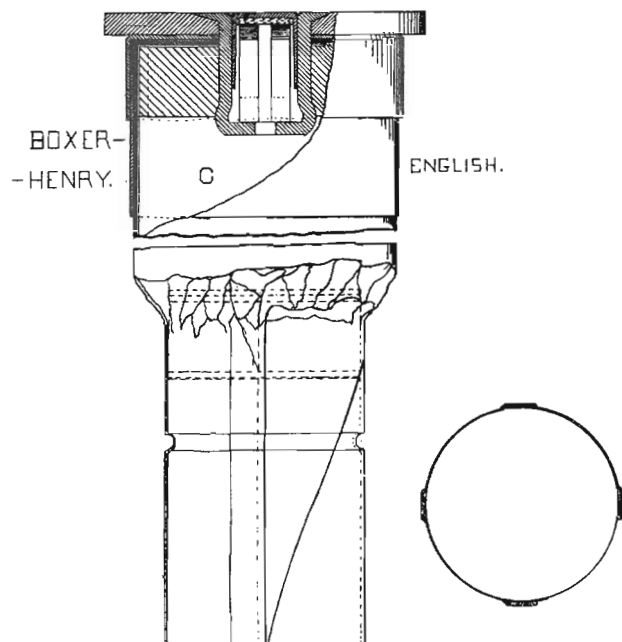

The late Genl. Rodman and Col. Cresspin, Carl. Definit. patented a wrapped metal cartridge in 1863, No. 10988, Pat. Off. Report of 1863. Claim.—The thin metal wrapped cartridge case made with edges not rounded, in combination with an internal or external strengthening disc or cup, made of paper, metal or elastic material, substantially as set forth. The case, Fig. A, is made on the above plan; blank forms, Fig. B, cut from strips of sheet metal made of required width and about .005 to .006 in thickness or less are wrapped by hand or formers; the end is folded over on the former to hold the case to the base; a paper washer is used in connection with curved priming cup and metal flange or head; a strengthening cup O prevents the unfolding of the metal on the cutting through at the extractor seat in firing.

The advantages claimed for the above case are strength of base, ease of extraction and cost. In the manufacture of about 12,000 in January and February, 1872, Col. Readwell dispensed with the paper washer, iron head and rivet cup, substituting a strengthening cup with a folded head and priming pocket made from continuous metal fastened to the case by solder. It is not proof against dampness; a number were packed in varnished paper boxes (service) and put into a damp cave for six months and were found to have lost about ten per cent initial velocity. A number of experiments have been made with these cartridges variously made, and with good results, and a considerable number issued for test in service and climate exposure.

A large number, see also described, Fig. A, were made by West of Springfield, Mass., during the Franco-German war. The case, Fig. C, is the celebrated English service Green-Spring cartridge case, made precisely on the same principle as the Rodman & Cresspin, differing only in having the strengthening cups and anvils instead of one and a strip of tin about (a copper strip has been substituted for this) 7 in. wide enclosed in the case below the first cup, as if for additional strength; the case is .65 in. diameter and reduced for a .45 calibre ball on end by folding in and lapsing the metal. A groove is made in the ball to secure it to the case. The cartridge has a rough and ungainly exterior and seems to be the product of unskilled mechanism, costing, however in England (See Report of Committee on Quick Loading Rifles, testimony of Col. Baker, page 22,) 4 & 7.5 a per 1000 rounds. Considering the difference in price of labor and material in England as compared with the United States it would cost here about 20 dollars per 1000, whereas a plain folded reinforced head made from drawn metal can be produced by the modern appliances for a much less sum and it is believed to be a more reliable cartridge in all respects.

## COL TREADWELL'S EXPERIMENTS. WRAPPED-METAL CARTRIDGE. CLASS 3.

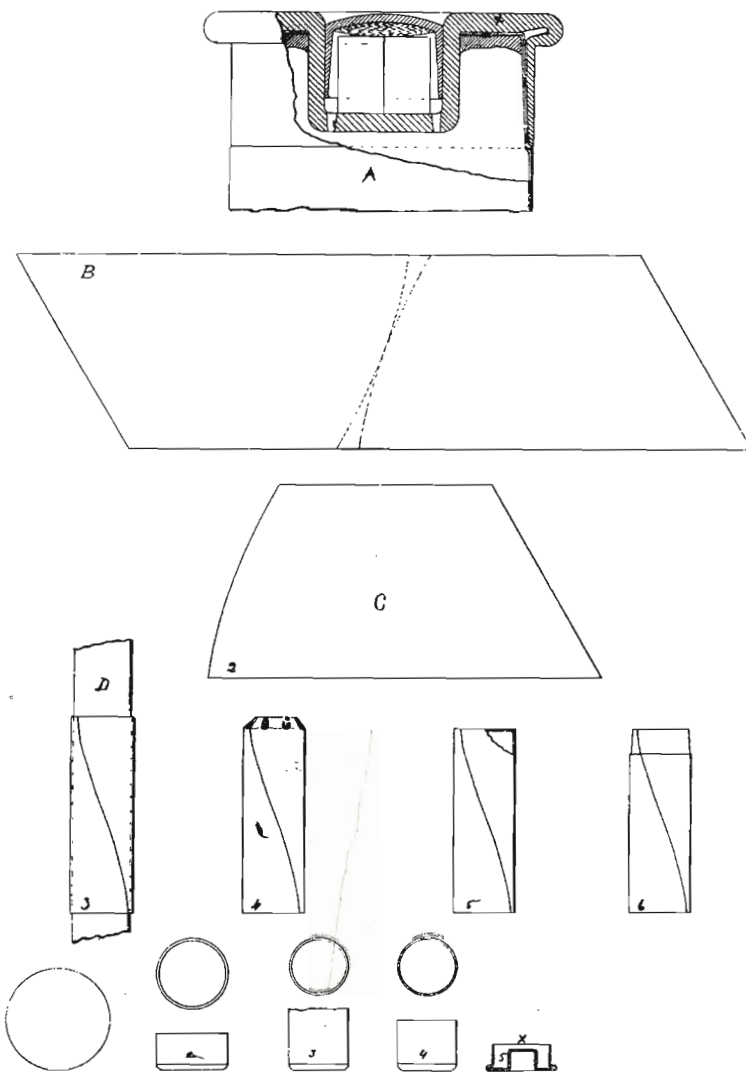

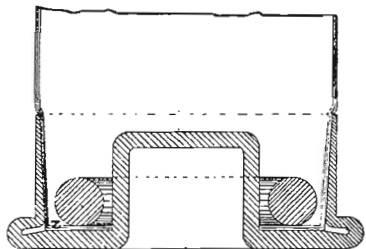

The case, Fig 1, is a departure from the ordinary mode of attaching a head and strengthening cup to a wrapped metal cartridge case. In lieu of the individual parts - the iron head with a hole in it, a strengthening cup, a rivet, priming cup and a paper washer - a head is formed with a pocket or a strengthening cup from continuous metal, as at Figs 1 to 5. Cutting from strips of metal the blank B is the first operation. 2<sup>d</sup> the blank wrapper cut to form C. 3<sup>d</sup> rolling on a former D 4<sup>th</sup> and 5<sup>th</sup> turning flange. 6<sup>th</sup> reducing end for strengthening cup. The cup at X is made in five operations. After the cup is placed on the case it is forced into a tapering die, closing in the cup at sides and perfecting the connection. It is then placed on plates holding 25 or more cases. A ring of solder is fed to the cases in like numbers and set home against the head. A drop of acid from the end of a plunger or can is then applied, the plates containing the cases placed on a heated surface, the melted solder forming its way under the fold of the cup, cementing the case and cup and forming a solid head. After washing they are vented and primed. About 12000 were made at this Arsenal for experimental firing and trial in service in January and February, 1872. About 500 were fired in the Springfield S.L. Rifle, cal. 50 and Gatling Gun cal. 50, showing no swelling of head or leakage and giving very easy extraction. In the experiment the solder melted and head burst with 80 grains of powder but stood well at 70 grains, showing surplus strength. The flange as at Z principally adds to the strength as it is a good gas check and in connection with the solder keeps the gas from acting on the fold on the head. The solder is not affected by the heat and pressure generated in the service cartridge, a number having the cups badly cracked in manufacture were fired without leakage or other injurious effects to the bomb. The number of operations in its manufacture are almost double that of the service cup (metal case), relatively the cost is about the same; the difference in weight of metal is in favor of a wrapped case, 25 grains; the slowness of some of its operations and the loss in manufacture will not be more than compensated for by the difference in metal. The use of acid is objectionable but is necessary for a proper flowing of the solder. The plant necessary for the manufacture of this case is inconsiderable as compared with that necessary in the production of ordinary cases, and its manufacture in urgency could readily be carried on at a number of Arsenals. It will not, it is believed, stand the test of climate, exposure to moisture and the accidents of service as well as a continuous ordinary case cartridge, but it is a valuable cartridge if destined to be used in a reasonable time after its manufacture. They would probably deteriorate in store unless secured in hermetically sealed boxes.

## COL TREADWELL'S EXPERIMENTS.

## CAST BASES.

## CLASS 3

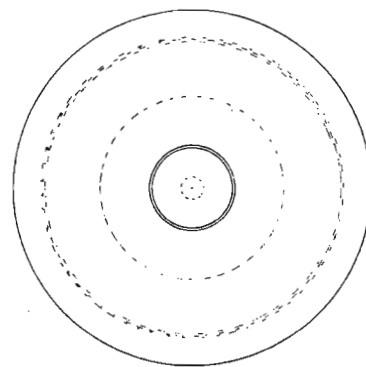
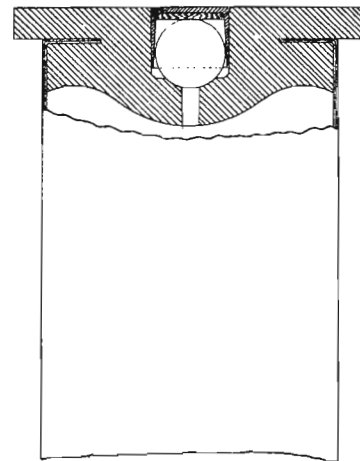

FRANKFORD

ARSENAL

FEB

1872

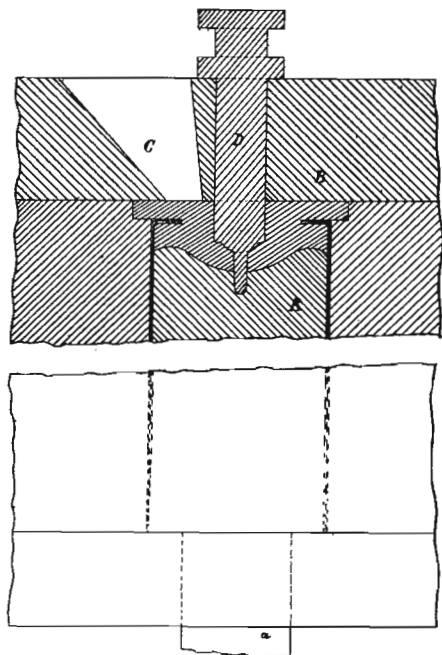

*Lead Cases.*—An experiment for casting a head or base on a cartridge case made from paper, foil or drawn metal was made at this Arsenal in February, 1872. It was thought that if a metal or alloy could be found that would flow into mold through small gates and be of such a character as to resist pressure in the gun and stiff enough to insure extraction, that such a case would be economical and could be made in an emergency with less plant and skilled labor than the ordinary drawn case. A case of wrapped foil metal with a flange was placed on a plunger piston in a mold, Fig. A, a pivoted top B containing the gate C and the pocket and vent-former D was made to shear off the gate after casting; the case was ejected by pressure in the bottom of the flange. A number of alloys made from lead, tin, bismuth, antimony and zinc were made. Considerable difficulty was experienced in casting these sluggish metals. A number of cartridge cases were cast of lead, lead slightly alloyed with antimony, type metal, and type metal with lead. Those of lead were fired in the Springfield gun their heads spreading to the limit of flange recess and failing to extract and those from type metal fused, breaking off the head in extraction, the metal being too brittle and no arrangement for casting under pressure being at hand, the trial was for the present discontinued. It is believed however that none of the above metals or their alloys are suitable for cartridge heads unless alloyed with copper or other metals of like nature, and that pressure would be necessary to flow the metal in a mold.

# HOTCHKISS'S SOLID HEAD.

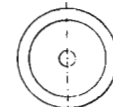
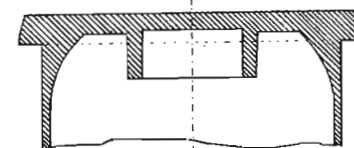
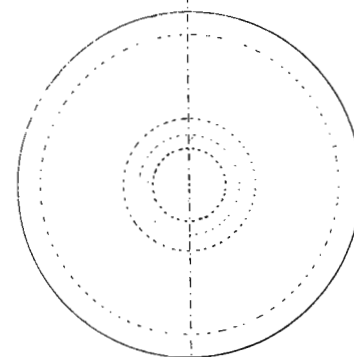
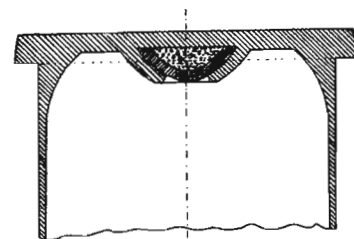

PATENTED.

EXPERIMENTAL

1868.

## BENET'S EXPERIMENTAL SOLID HEAD.

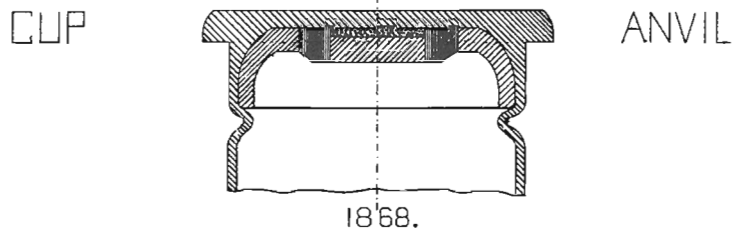

### Remarks.

The cup anvil for service cartridges was introduced and successfully applied by Col. S. V. Benet, Comdg. Frankford Arsenal, March, 1868. It was made from lined sheet iron as an experiment; the crown was indented to hold the priming, with slots for ignition; to keep and support it in place the copper was crimped under its edges. Its superiority over the bar anvil is as follows:— 1<sup>st</sup> The cup anvil being cylindrical in form furnished more surface at its edges to crimp under, making it more rigid and permanent and greatly increasing the certainty of ignition. 2<sup>nd</sup> The crimping and forcing the copper from the sides of the case at a greater distance from the flange considerably lessened the strain at or near the fold, giving a greater strength at head and a smaller percentage of burlings at fold. 3<sup>rd</sup> The impossibility of getting the priming up side down, as was sometimes the case with the bar anvil.

The weak point of the cup anvil cartridge is at the fold, & if not being supported in the gun as other parts of the case, depends on its own inherent strength; the bending of the metal causes stretching on the outside and a closing on inside at fold, and occasional fracturing and downsliding according to the quality of metal. (See diagram detail.)

Sheet metal is not free from such defects as seams, flaws, &c. which, not appearing on the surface, escape inspection, developing only when the cartridge is fired.

Col Benet experimented with solid heads which gave sufficient strength, but their manufacture was difficult and expensive.

A series of experiments conducted by Col. T. J. Drennells, Comdg. during 1871 and 1872 proved that the head was strengthened by the use of sundry devices contiguous to head. (See Drennells experiments.) Further experiment proved that the only reliable mode of reinforcing is by the use of a gas check, as proposed by Col. Burton in 1867, preventing the direct action of the gas at fold.

The lined cup anvil in damp and salt atmosphere was subject to oxidation thereby destroying the priming composition; it was abandoned August, 1870. Copper was substituted and is now exclusively used for anvils and is not liable to the above defect. Machinery is applied to all the operations in the manufacture, producing a cartridge whose excellence and certainty of fire is not surpassed by any of the various kinds made for the trade. Dimensions of sheet copper for case .028 in. thick, 3.3 in. wide, in strips 36 in. long. Sheet copper for cup-anvil .015 in. thick, 2.75 in. wide, in strips 25 in. long.

Frankford Arsenal, Pa.  
January, 1872. }

## EXPERIMENTAL.

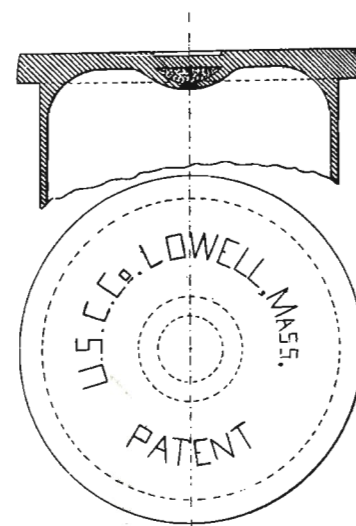

### Remarks.

A number of solid head cartridges, (patterns presented by Mr. Kootchise) were made here in November, 1868, Col. S. V. Benet, comdg. The cases were drawn from sheet-copper .07 in. thick; they were placed on a spindle grooved at end and forced into a die; pressure being applied caused the copper to flow forming the pocket and flange at head. A small concave disc vented in centre to hold the priming was inserted into the pocket and held in place by turning over the sides of the pocket on to it. The great pressure, (about 60,000 lbs.) required to flow the metal at end of case upset the inside supporting spindle, shortening its length and thereby producing various thicknesses of metal at the point of ignition, also hardening the metal and retarding the action of the firing pin, resulting in a larger percentage of miss-fires than is allowed for a service cartridge. Drawing the case from so thick a metal as .07 in. does not give as uniform and concentric a case as with the thinner metals and causes a larger percentage of loss in work. The record of firing at this Arsenal gives 10 per cent miss-fires with the anvil vented in the centre, and 5 per cent of those vented with two holes. A number sent here for trial from the U. S. Cartridge Co., Lowell, Mass. failed at the rate of 10 per cent. Col. Benet applied the cup anvil to these solid heads and fired 350 without failure.

An anvil fixed inside of a case requires rigidity in proportion to the thickness of the metal through which the blow is transmitted in connection with acuteness of point of firing pin.

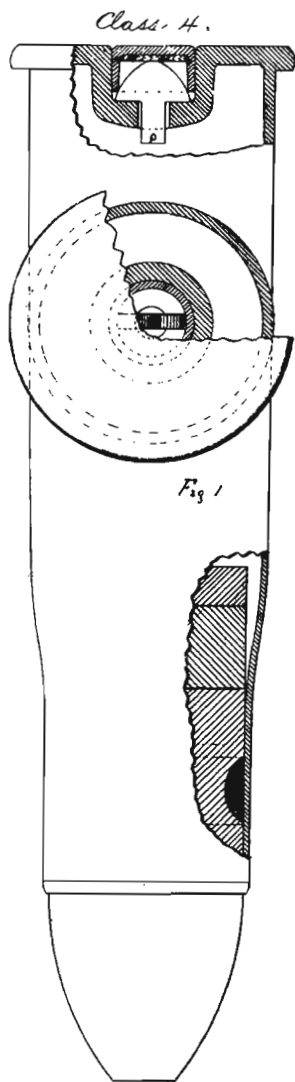
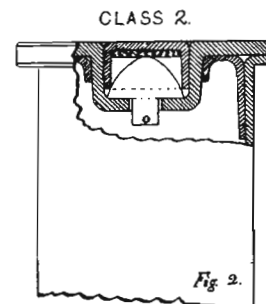
DUTCH MUSKET  
CARTRIDGEDUTCH CARBINE  
CARTRIDGE.*Remarks.*

The above cartridges Figs 1 and 2 were used in connection with guns sent from Holland in experimental of the Calibre Board at this Arsenal. They are designed for reloading shells, - the peculiar feature being the anvil, the leg or handle of which projects through the vent in pocket at O to facilitate the extraction of the exploded primer by pressing on the leg from inside, the cap is easily ejected, a new cap is then inserted on the same anvil and the case reloaded with powder and ball - The case is of brass, the anvil and primer of copper, the composition of a black color supposed to be in part of meal powder. Workmanship on carbine case indifferent; the primer leaks gas owing to the side of cap being too thick to be expanded readily. The anvil being made of thin metal and having too small a base sideways is liable to lie off from the centre of the cap causing mis-fires. The metal at the fold of head in the carbine case is pressed too hard causing a demoralization and if it was not protected by the re-forcing cap it would very frequently burst open in the flange. It is also objectionably squared in finishing. The features of the solid case present no new points. The same bullet is used in both cartridges, weight 310 grains; weight of charge of the musket 70 grains, carbine 50 grains.

## FARRINGTON'S PRIMER.

SOLID HEAD  
CARTRIDGE

U. S. CARTRIDGE CO.      LOWELL, MASS.

CLASS 4.

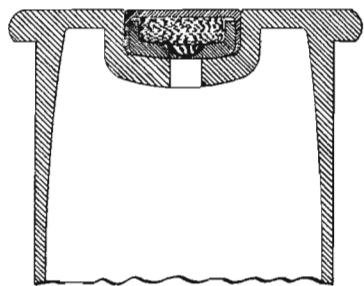

FARRINGTON'S

IMPROVED.

*Patented Dec'r 1872. No. 133,929.*

## Remarks.

At a trial of the above cartridges in comparison with service cup-anvil cartridges some 630 rounds of each were fired, to test the certainty of ignition, in Springfield and Remington rifles with but one failure to explode, (a Lowell cartridge failed) having no fulminate in primer. 100 rounds of each were also fired in the 50 calibre Gatling gun without failure.

The extraction of the solid brass case was easy. An improvement of the primer has recently been invented by Mr. Farrington as shown in the small figure. The bullets of the Lowell ammunition were turned from lead wire; their variation in weight was considerably greater than that of the service pressed bullet and in some cases their grooves were considerably eccentric and of variable depth. The mean absolute deviation of twenty rounds being with Springfield gun at 500 yards

U. S. Cartridge Co. Ammunition, 1.775

Service cup-anvil, do, 1.156

With Remington gun at same range:

U. S. Cartridge Co. Ammunition 1.722

Service cup anvil do 0.980

The solid head case makes a most excellent cartridge and could doubtless be used many times as a reload if desired.

FRONT LUBRICATION  
NAVY EXPERIMENT.

CLASS 4.

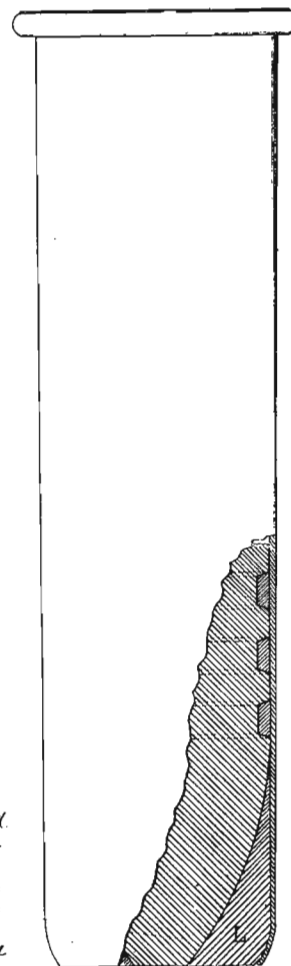

Farrington's Patent, Dec. 31, 1872.

I. Lubricant of Japan wax and tallow.

## Remarks

The above are solid differing from those described length of case and front case is reduced on the lubri.

The following pro- testing the above cartridges, object being to ascertain the after a certain number of

head brass case cartridges on preceding page only in lubrication; the front end of can't be held in place. grammie. was carried out in with service, the principal amount of fouling deposited rounds had been fired.

1<sup>st</sup> Series. { 103 rounds of service ammunition, Remington gun, gave fouling .. 23.9 grains.  
                  { 103 " Lowell do. do. long chamber " " 11.2 "

2<sup>nd</sup> Series. { 100 rounds of service ammunition, Springfield gun, gave fouling 12.2 "  
                  { 100 " Lowell do. do. long chamber " 13.3 "

These two last guns are now fouled by 100 rounds each with its own ammunition and are again fouled by an additional 600 rounds each - in all this last series (3<sup>rd</sup>) 700 rounds each without cleaning.

3<sup>rd</sup> Series. { 700 rounds of Lowell ammunition, Springfield long chamber, fouling 21.2 grains  
                  { 700 do. service do. Springfield gun " 16.0 "

The last series, (as the figures will show) throw no additional light on the subject in question. One Lowell cartridge failed to explode - cause - had no powder charge.

Fired in all 803 rounds Lowell ammunition.

" " 803 " service do.

## FRONT LUBRICATION

EXPERIMENTAL

FRANKFORD ARSENAL.

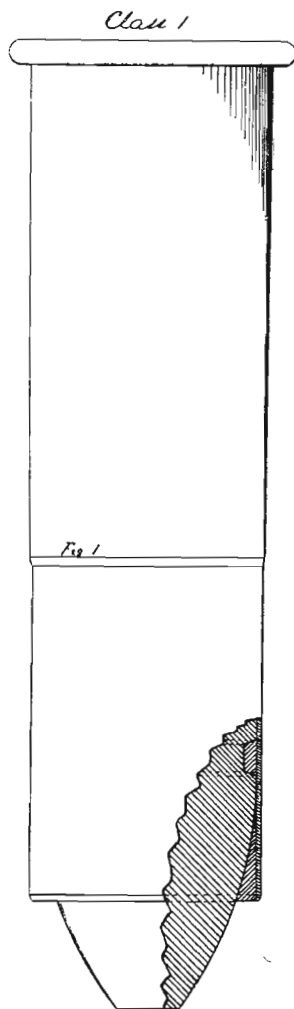

1865 -- 1869.

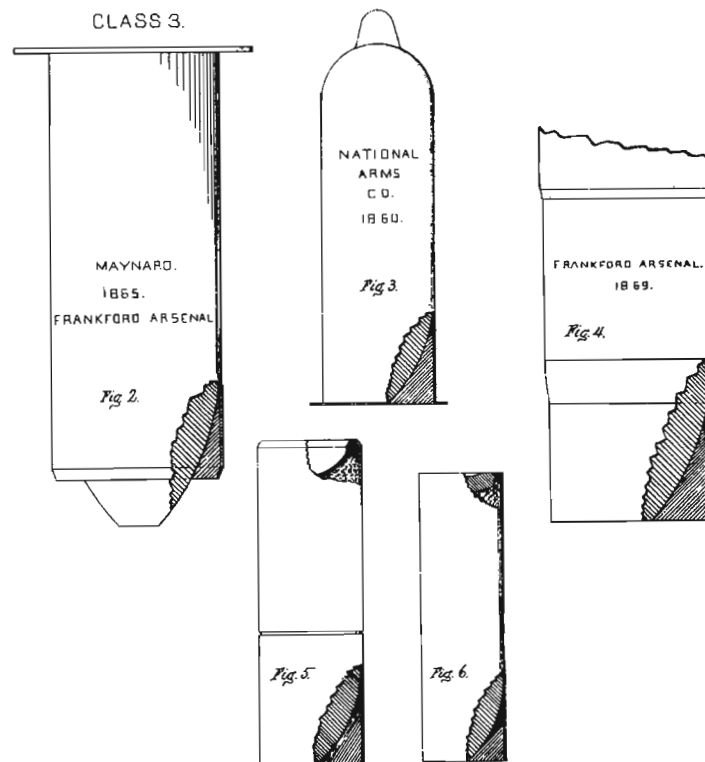
*Remarks.*

In the early part of 1865 a large number of the Maynard Metallic cartridges were loaded at this Arsenal by means of machinery specially made for assembling the case, powder and ball; as no provision was made for the paper wad at the base of the ball it was left out together with the lubricant on the ball, substituting front lubrication as is shown at Fig. 2. The ball being partially enclosed in the case only about one fourth of the conoidal part projecting, leaving between it and the case space to receive and hold the lubricant. About the year 1860 the National Arms Co. of New York made a cartridge for a Revolver Pistol, as is shown at Fig. 3. Figs. 5 and 6 are also experimental samples of Pistol cartridges with front lubricant. In 1869 several devices were made and experimented with at this Arsenal, Figs. 1 and 4. The former gave excellent sustained practice for 100 rounds, the fouling being 7 grains; it was objected to as presenting a square front to the chamber in inserting the case. The latter was not tried, but was suggested by Mr. Gill as a means of better securing the ball than No. 1. The general practice with any mode of front lubricant is good as far as sustained firing is concerned, and with all lubricants as has been frequently determined by experiment on many occasions.

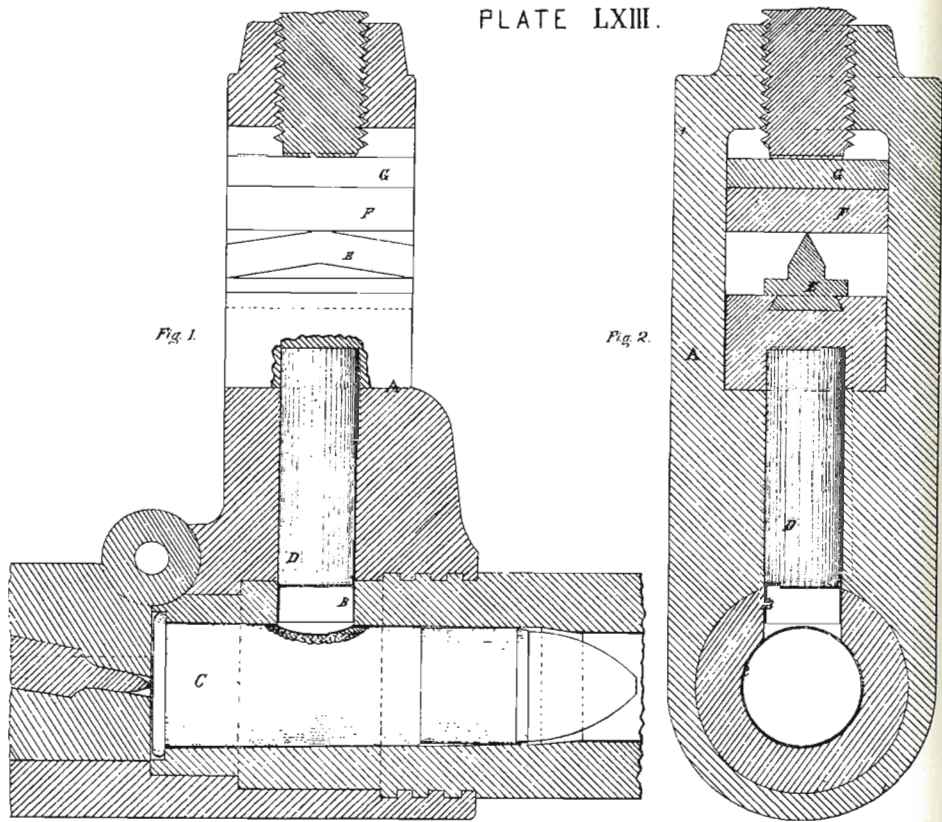

PRESSURE S.  
SERVICE GUN AND CARTRIDGE.

The application of the "Redman" pressure gauge to the Springfield gun is shown in Figs. 1-2. The usual breech arrangement of the gun should have added a projecting frame A, specially made for strength and accommodation of the piston D, knife F, and copper and steel plates F and G. A gas check B is used to prevent the escape of gas at the piston D. The cartridge C has a hole in its side the same size as the piston D (area to square inch); the edges of the hole in case are required to be made thin by a special operation, and lay snugly to the side of chamber to prevent the escape of gas. No reliable results can be obtained if the gas is allowed to escape at this point. A slip of paper is inserted into the case to prevent the powder from falling out; the charge is ignited in the usual manner; the gas forces the piston D against the knife F into the copper plate F making a cut, the knife and copper are removed to a weighing machine and a corresponding cut of equal length is made in the same copper. A record of 50 shots gave a maximum of 14,000 pounds and a minimum of 12,000 lbs. Above 13,000 lbs. per square inch for the service cartridge: - 70 grains powder, .450 qv. Ball.

RELATIVE PRESSURES  
CRIMPED. VS NOT CRIMPED  
CASE.

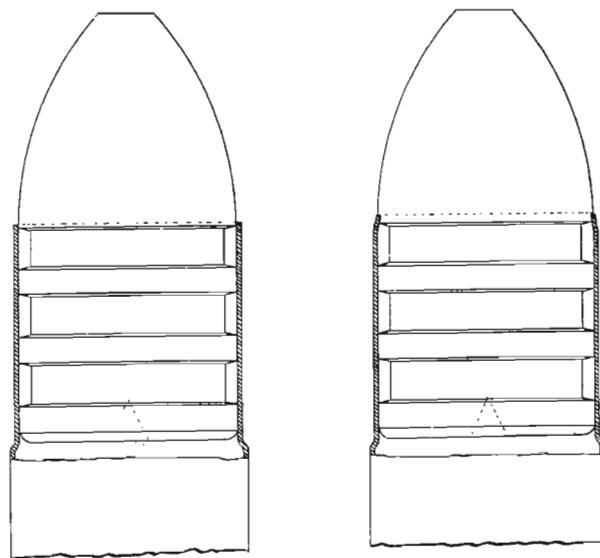

The object of crimping or closing the end of a cartridge case tightly upon the bullet is to insure it against the shock of transportation, the exigencies of service and to exclude moisture. Crimping increases the pressure and consequent strain on the case. With the service ammunition the pressure with crimped case is from two to three thousand pounds per square inch greater than without the crimp and in about the same ratio with calibres .45 and .42. 25 shots of three several calibres, crimped case, gave a mean of 2300 lbs. per square inch greater than the case not crimped. The velocity is also increased by the use of a crimped case, but not in the same ratio as the pressures; 15 shots of the same calibre gave a mean increased initial velocity of 30 feet per second.

COL. TREADWELL'S EXPERIMENTS. PLATE LXV.  
RELATIVE PRESSURES.  
REDUCED v.s. STRAIGHT  
CASE.

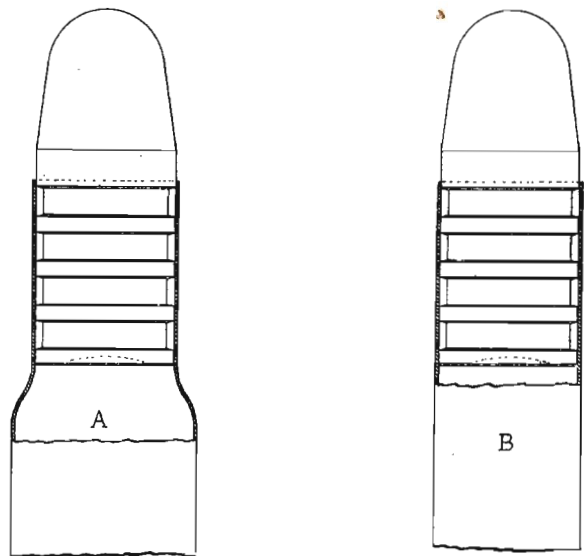

A mean of 10 shots, Cal. .45, Bottle-shaped Cartridge Case, No. 270 ammunition, charge 70 grs. Musket Powder, 100 grs. Bullet, gave a pressure of 18,500 lbs. per square inch.

A mean of 10 shots, Cal. .45, Straight Cartridge Case, No. 272 ammunition, charge 70 grs. Musket Powder, 100 grs. Bullet, gave a pressure of 16,300 lbs. per square inch.

A mean of 10 shots, Cal. .42, Bottle-shaped Cartridge Case, No. 271 ammunition, charge 65 grains Musket Powder, 370 grs. Bullet, gave a pressure of 17,150 lbs. per square inch.

A mean of 10 shots, Cal. .42 Straight Cartridge Case, No. 273 ammunition, charge 65 grs. Musket Powder, 365 grs. Bullet, gave a pressure of 16,250 lbs. per square inch.

In a reduced or Bottle-shaped case (I once straight case Cal. .50 reduced for .40 and .45 calibers) as at A, the pressure is greater than in a straight case as at B, both having the same weight of powder and ball.

CANNON LOCK  
FOR  
GAS CHECK PRIMER S.

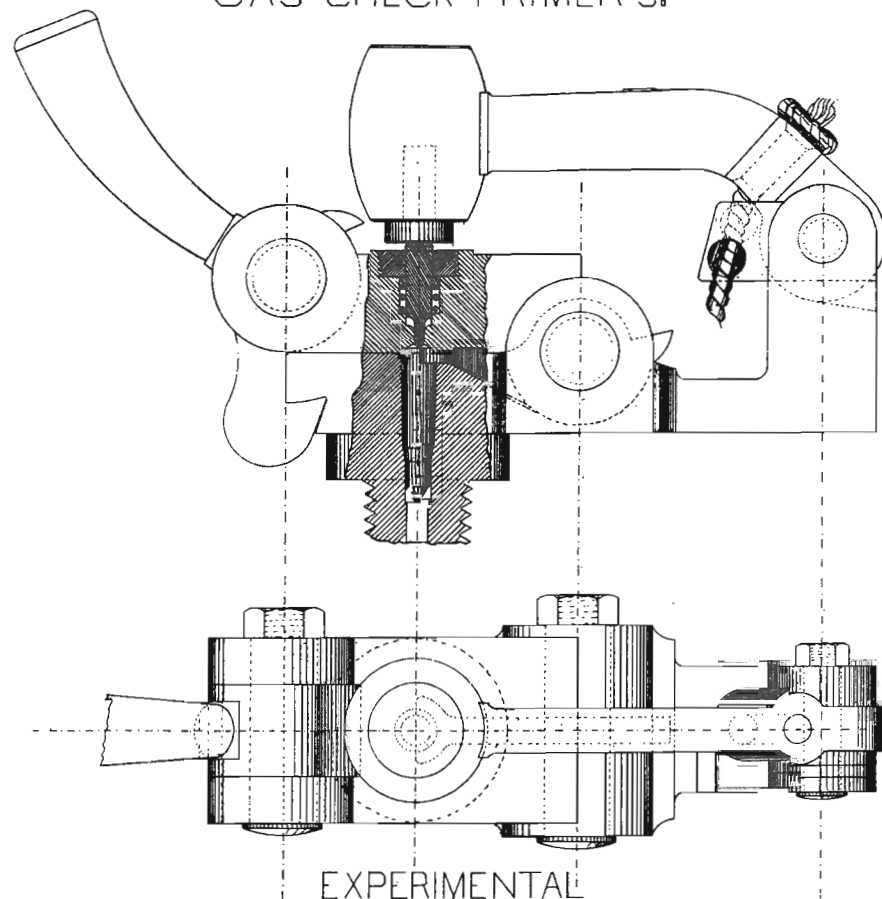

Remarks:

This Lock was designed and constructed at this Arsenal, in October, 1869, Col. J. F. Treadwell, comd'g, and was used at the experimental firing of heavy ordnance at Fort Monroe. Previously locks of two different patterns were made and failed to protect the primer. The peculiarity of the Frankford Lock is the concavity of the breech-block at the firing pin, which prevents the heavy gas pressures in the gun from punching through the metal at that point, and supporting the primer head in connection with the rounded point of the firing pin; without this cavity the hole for the firing pin acts as a die and the pressure as a punch, cutting through the metal at that point, at pressures above 25,000 lbs. per square inch.

GAS CHECK PRIMER  
FOR CANNON IGNITION.

SOLID  
HEADS

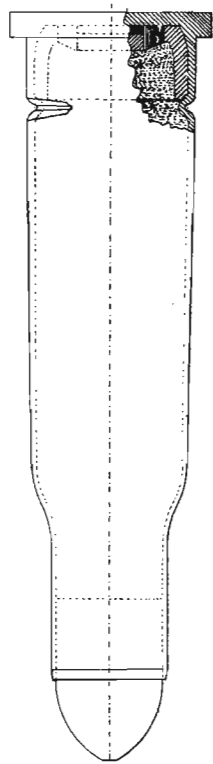

BY  
SPINNING.

OCT. 1869  
EXPERIMENTAL

Remarks.

Gas Check Primers for cannon, as suggested by the Ordnance Board, 1868, were made at this Arsenal in October and November, 1869, Col. T. J. Drendell, comd'g. At their trial at Fort Monroe the folded heads burst and cut through at the joining pin, owing to the great pressure in the gun. A solid head was then made by both pressing and spinning on the flange; the object of spinning was to relieve the inside supporting spindle of the heavy pressure required in forming the heads by pressure, which caused repeated upsetting and breaking of the spindle. The copper case was placed on a spindle and then covered by a die, by revolving the spindle rapidly, pressing at the same time with a sawed edge tool held stationary against the end of the copper case, the metal flowed and formed the flange at head easily; constant lubrication was necessary but still the metal would sometimes stick fast on the round edge causing abrasions and tearings. 100 were made and worked well withstanding a pressure of 100,000 lbs in the Rifle Guns.

SPRINGFIELD  
BREECH LOADING RIFLE  
CHAMBER AND CARTRIDGE  
CAL .50

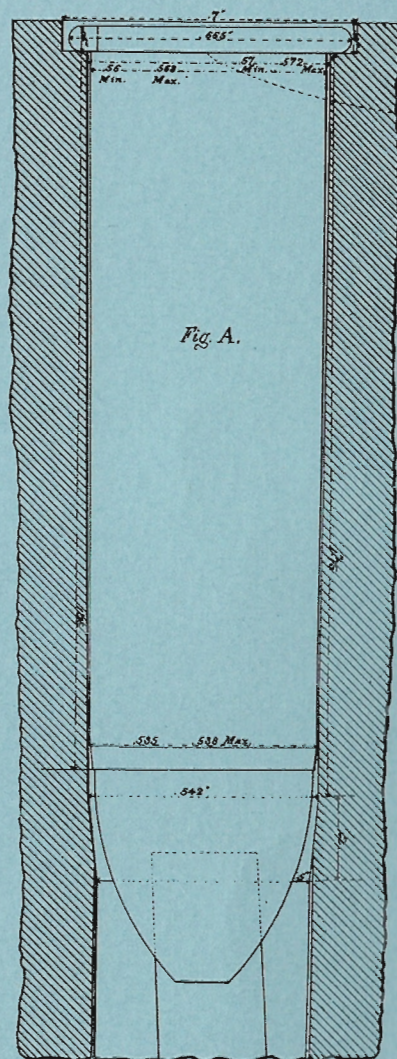

Fig. A.

The diameter of recess of the gun should be of cartridge so as not or extractor, nor can flange of cartridge be of recess. As an maximum size of manufacture of the millions thence the same is also of the chamber and case, and case, Fig. A, are desired to work to. of chamber must not elasticity of the metal case can have a greater variation than a copper one and extract easier with less taper as it is more elastic. The taper of a case should be as slight as it is possible to extract freely, the more tapered it is the more severe is the operation of manufacture on the head and sides, oftentimes closing the head with enlargement of diameter and increasing in thickness; the longer the case the greater resistance or friction is offered by the die.

for head in chamber larger than the head to interfere in loading the thickness of the case great as the depth allowance beyond the necessary on the mouth of both gun and cartridge of all the diameters. The sizes of chamber about as close as it is the excess of diameter be beyond the limit of of the case; a brass